

VAN DER VALK



Installation manual



Valk**Pitched** Clamp - Tiled roof

Version: v1.3
Date: 01-12-2022

Disclaimer

This installation manual needs to be stored for future use. For project specific guidelines and recommendation it is required to use this document in conjunction with the "Project report" generated by the ValkPVplanner. The instructions provided in this Project Report must be strictly observed at all times.

The content of this installation manual has been carefully compiled. Van der Valk Solar Systems does not accept any liability for the correct use of this document. Van der Valk Solar Systems hold the right to update the content of this document without further notice. Please check the website of Van der Valk Solar Systems (www.valksolarsystems.com) for the most recent version of this document.

For the warranty conditions of your installation, please contact your supplier. Further we refer to our General Terms and Conditions, that are available upon request.

General installation guidelines

General

- During installation of the solar mounting system, the instructions and safety precautions presented in this installation manual must be followed carefully. As also stated in the General terms and Conditions of sale and delivery of Van der Valk Solar Systems B.V., non-compliance with the installation guidelines in this document means that the customer can no longer invoke any warranty and Van der Valk is no longer liable for any form of damage.
- The information, comments and advice in this document are binding. Van der Valk Solar Systems reserves the right to update this document without further notice.

Safety

- The installation of the mounting system must be carried out by qualified technical personnel.
- Omitting parts may negatively affect performance and is therefore not allowed.
- Avoid carrying out installation work during bad weather conditions, especially in case of strong winds and a wet (slippery) roof surface.
- During installation work on the roof, always use fall protection and, if necessary, work with safety nets and roof edge protection.
- Always wear appropriate protective clothing and gloves when carrying out the installation work.
- Follow the guidelines in the publication "Health & safety in roof work".

Environmental factors

- High neighbouring buildings or objects, such as windmills, can affect the wind pressure. In these cases, advice should always be obtained from Van der Valk Solar Systems before installation can take place.
- If during the installation it is determined that the project data and/or environmental factors do not fully correspond to the project report, the project must always be re-calculated first.
In coastal areas, the system should be placed at least 500 meters from open water to prevent accelerated corrosion by the action of salt water. When buildings are present between the open water and the roof, a minimum distance of 250 meters from open water may be maintained.

Standards and regulations

VAN DER VALK



- For correct and safe installation and use of the solar mounting system, always observe the applicable standards and regulations:
 - EN 1990: Basis of structural design
 - EN 1991-1-3: General actions: snow loads
 - EN 1991-1-4: General actions: wind loads
 - IEC 60364: Electrical Installations for Buildings
 - IEC 62305: Protection against lightnings
 - EN 50110: Operation of electrical installations
 - Working Conditions Act and Safe Working Conditions Regulation

Stability and condition of the roof and roof covering

- The roof pitch should be less than 5 degrees for flat roof systems and between 5 degrees to 75 degrees for pitched roof systems.
- The condition of the roof must be checked upfront for sufficient strength to bear the weight of the mounting system including PV panels ballast and wind and snow loads. Make sure that the load reserve of the roof is not exceeded anywhere.
- Check the stability of the roof and adjust the roof/construction where necessary.
- Check prior to installation whether the roof covering and/or insulation is suitable for the pressure and thermal expansion of the solar mounting system. The maximum pressure is shown in the project report of the ValkPVplanner or can be requested at Van der Valk Solar Systems.
- Bulging of the roof membrane should be prevented. This can lift the solar mounting system and can cause displacement of the mounting system or ballast. It is the installer's responsibility to prevent the roof membrane from bulging.
- Factors such as overhead cranes, seismic activity and others that affect the stability of the roof and/or building can affect the installed solar mounting system. Van der Valk Solar Systems does not take these factors into account, unless confirmed in writing.
- The roof surface on which the solar mounting system is to be installed must be clean, dry and flat.
- The roof height may not exceed 25 meters in case the project has been calculated in the ValkPVplanner must be corresponding to the roof height in the project report. For installations on roofs higher than 25 meters, Van der Valk Solar Systems should always be contacted in advance.

Roof zones

- When installing the solar mounting system, always take the applicable roof zones according to EN1991-1-4 into account. Placing solar panels in the edge zone of the roof (the distance measured from the roof edge, which is equal to 1/5 of the building height) is only possible if this has been explicitly taken into account in the calculation.
- It is possible to position panels in the edge zone of the roof in the ValkPVplanner (calculation software), on the basis of which the required additional ballast or fixation points are automatically calculated. This can only be done using "Satellite" or "White Map" design mode. The edge zone is automatically calculated by the ValkPVplanner, based on the roof height and building circumference, in accordance with the applicable regulations. In case the design mode "Simple mode" is used, the calculation always assumes that the solar panels are in the middle zone of the roof only.
- In case solar panels on the ValkPro+ system are fully or partially placed in the edge zone of the roof, it is mandatory to use side plates.
- ValkKITS (ValkBox3, ValkDouble, ValkTriple, ValkQuattro) can only be placed in the middle zone of the roof. Placing these systems in the edge zone of the roof is not allowed.

Dilatations

VAN DER VALK



- The maximum allowed dimensions of a coupled mounting system is a 30 meters in the aluminium direction and 60 meters in the steel direction. The maximum dimensions are based on the thermal expansion in case of a maximum temperature difference (Delta T) of 70 degrees Celsius.
- The coupled mounting system must not be placed over a gutter or ridge. In the mounting system is place over a gutter or ridge, the system must be split (dilatation).
- When using the extra wide panel support feet for ValkPro+ with ballast, different dilatation rules apply: in such installations the coupled system may be a maximum of 30 meters in the steel/roof carrier direction and 15 meters in the aluminium direction.

Solar panels

- It is the responsibility of the installer to determine in advance whether the selected solar panel is suitable for the mounting system in terms of dimensions and pressure loads. The calculated loads on the solar panel are shown in the project report of the ValkPVplanner or are available on request at Van der Valk Solar Systems.

Cable management

- In order to create a sound and durable electrical connection between the solar panels, it must be ensured that the cables from the junction box have sufficient length and thus do not cause any mechanical stress on the cable glands. Take into account thermal expansion and contraction of cables and the mounting system.
- Cables and connectors must be kept away from sharp and/or abrasive parts and the roof surface by using sufficient and appropriate cable clamps and cable baskets.

Disassembly and Removal

- Components of the solar mounting system can be easily and completely disassembled at the end of their service life and separated for recycling. The systems only contain nut and bolt, screw and click connections, so nothing is glued or welded. All materials are fully recyclable. Disposal of the components always in accordance with the locally applicable laws and regulations.

Table of contents:

Disclaimer	Page 1-3
Table of contents	Page 4
Recommended tools for installing Pitched roof - Roof tiles [Clamp]	Page 5
Required materials for Pitched roof - Roof tiles [Clamp]	Page 6-7
Overview standard roof structure	Page 8
Overview roof hooks	Page 9-10
Mounting Smartline roof hook	Page 11-12
Mounting Slimline roof hook	Page 13-14
Mounting Strongline roof hook	Page 15-16
Mounting aluminium profiles	Page 17-18
Coupling aluminium profiles	Page 19-20
Mounting end clamps	Page 21-22
Mounting panel clamps (middle)	Page 23
Cable clamps	Page 24-25
Mounting optional products	Page 26-27

VAN DER VALK



Required tools for installing Pitched roof - Roof tiles [Clamp]



Cordless drill



Socket 13mm
Wrench 13mm

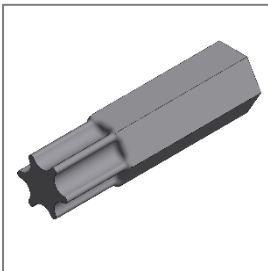

Torx bit T-30
(789530)

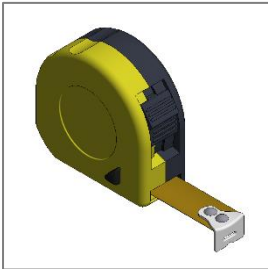

Measuring tape

Materials for installing Pitched roof - Roof tiles [Clamp]

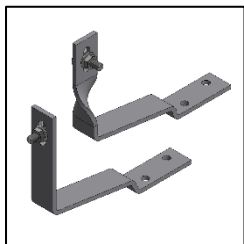

Smartline roof hook
(747831) - standard
(747832) - twist

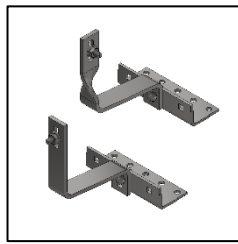

Strongline roof hook
(747844) - standard
(747845) - twist

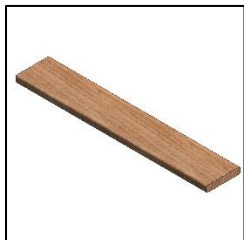

Construction wood 730mm
(75400730)

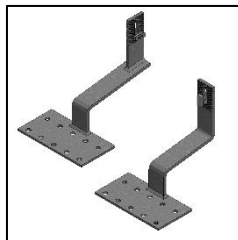

Strongline Heavy Duty roof hook
(747838) - standard
(747839) - twist



Ss torx-screw 5,5x38mm
(773840)



Ss torx-screw 5,5x58mm
(773360)

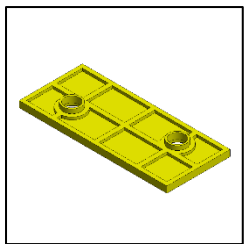

Plastic shim 3mm for Smartline
roof hook
(739003)

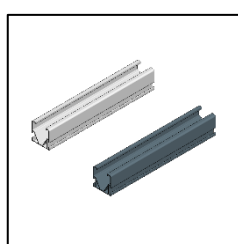

Aluminium side++ profile
(7017.....*)
*see table

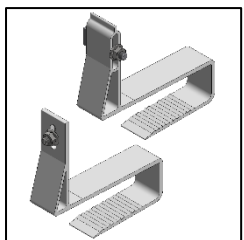

Fixed Slimline roof hook
(729530) - standard
(729531) - twist

Profile length	Art no. Blank profile	Art no. Black profile
1220 mm	701701220	
2370 mm	701702370	701702370ZW
3520 mm	701703520	
4670 mm	701704670	
5820 mm	701705820	

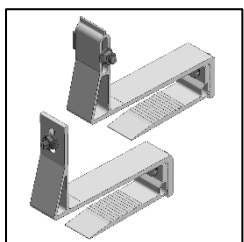

Adjustable Slimline roof hook
(729540) - standard
(729541) - twist

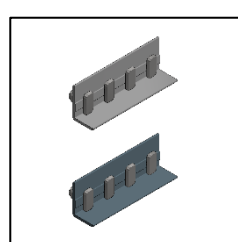

Coupling piece side++ profile
(724863) - Blank
(724863ZW) - Black

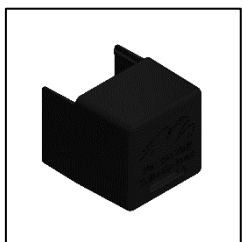

Plastic end cap for side++ profile
(739052)

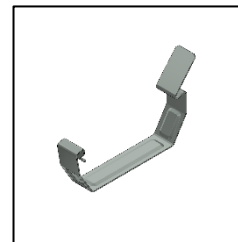

Ss cable clamp large
(732005)

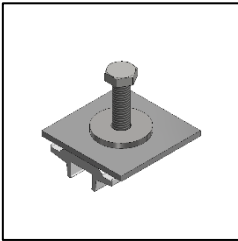

Optimizer clamp for side++
profile
(774223)



Panel clamp covers
Middle - (739006)
End - (739007)

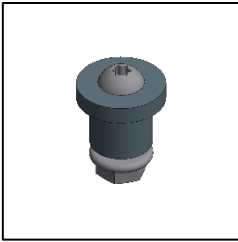

Plastic panel alignment pins
(733020)

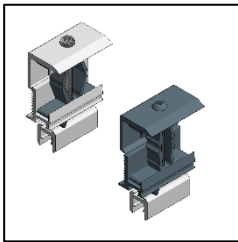

Aluminium end clamp 28-50mm
(721552) - Blank
(721552ZW) - Black

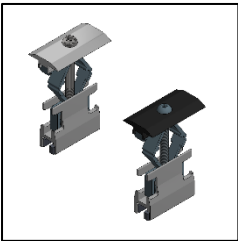

Aluminum mid clamp 28-50mm
(721550) - Blank
(721550ZW) - Black

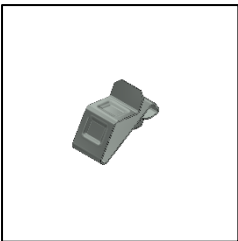

Ss cable clamp small
(732001)

Overview standard roof structure

The mounting system in this manual will be mounted on a standard roof with roof tiles. In the manual some of the parts of the roof structure are mentioned. In the image down below you can find the names of each part that is being mentioned in the manual.

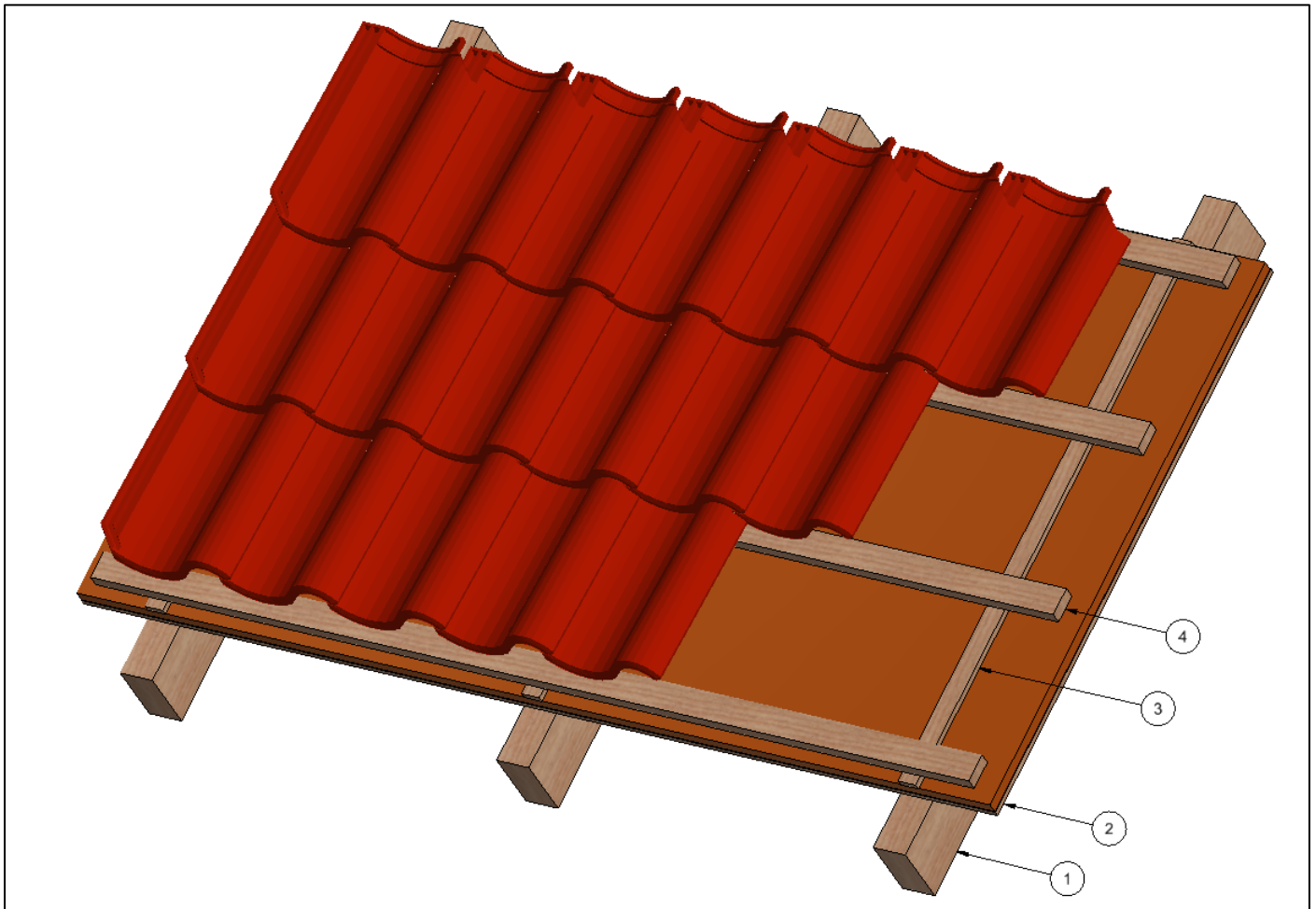

- 1) Purlins
The purlins are the structural beams that supply the strength and shape of the building.
- 2) Roof boarding
The roof boarding is the waterproof layer of the roof. Most of the times the roof boarding is also provided with insulation.
- 3) Rafters
The rafters are connecting all other part of the roof together. The rafters are fixed through the roof boarding to the purlins. On the rafters the battens are mounted.
- 4) Battens
The battens are fixed on the rafters. The battens are used as support for the roof tiles.

Overview roof hooks

Smartline roof hook

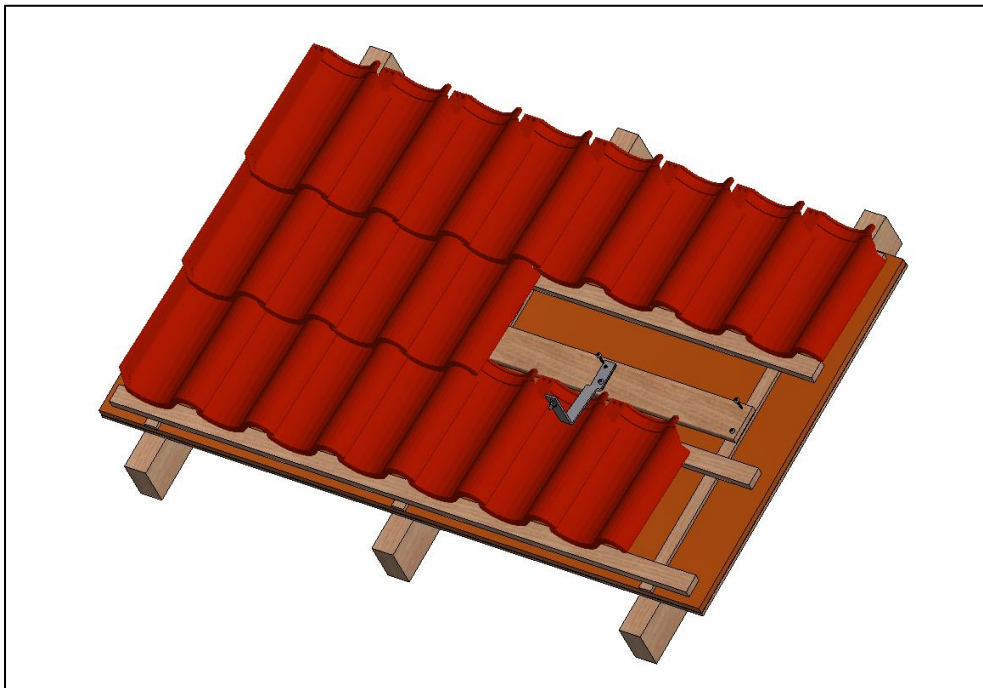

The smartline roof hook is used in combination with the wooden plank. The wooden plank is mounted on the purlins of the roof, the Smartline is then mounted on the plank.

Slimline roof hook

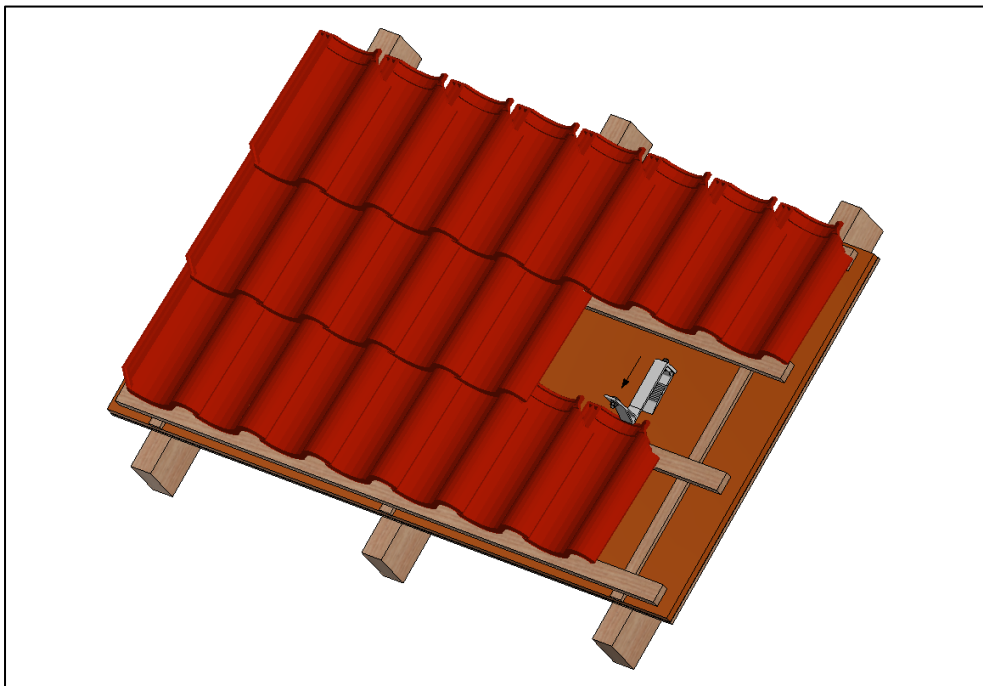

The Slimline roof hook is not fixed with screws. It is simply placed over the roof tile and rafters. Because the roof hook is not 'fixed' the mounting is much faster, but the strength in comparison to the other hooks is less.

Strongline (Heavy Duty) roof hook

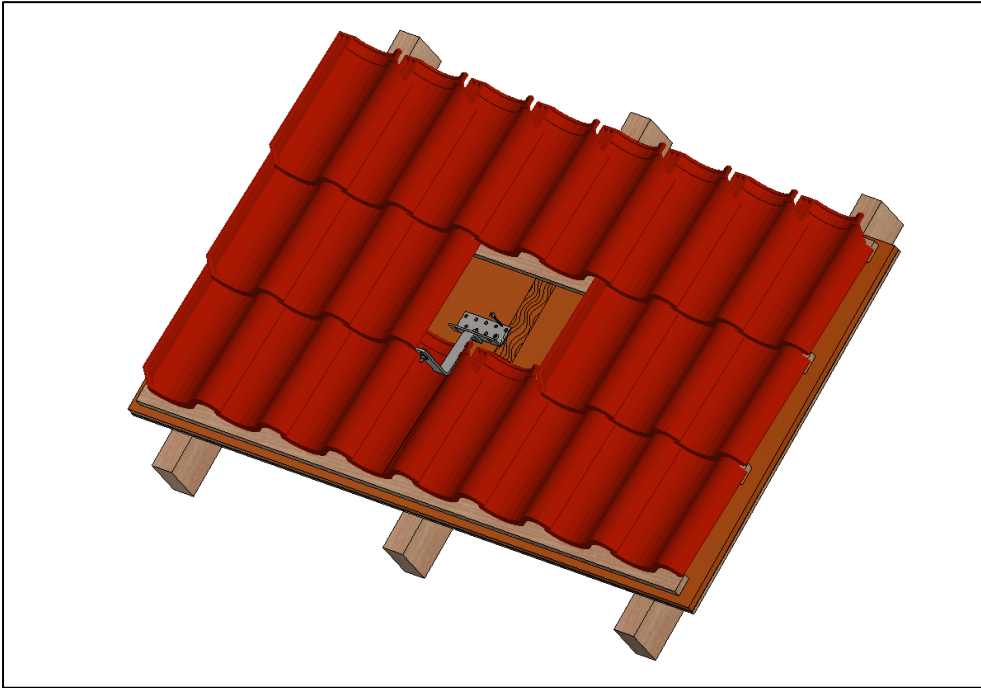

The strongline roof hooks are fixed on the purlins of the roof. The mounting plate has multiple holes for the screws. The standard strongline hook has 3 adjustable options available.

Mounting Smartline roof hook

Fix the wooden planks over the rafters with at least 4 screws. The roof hook is placed on the wooden plank with the same screws. Make sure the roof hook are aligned properly so the profile can be mounted correct at all times.

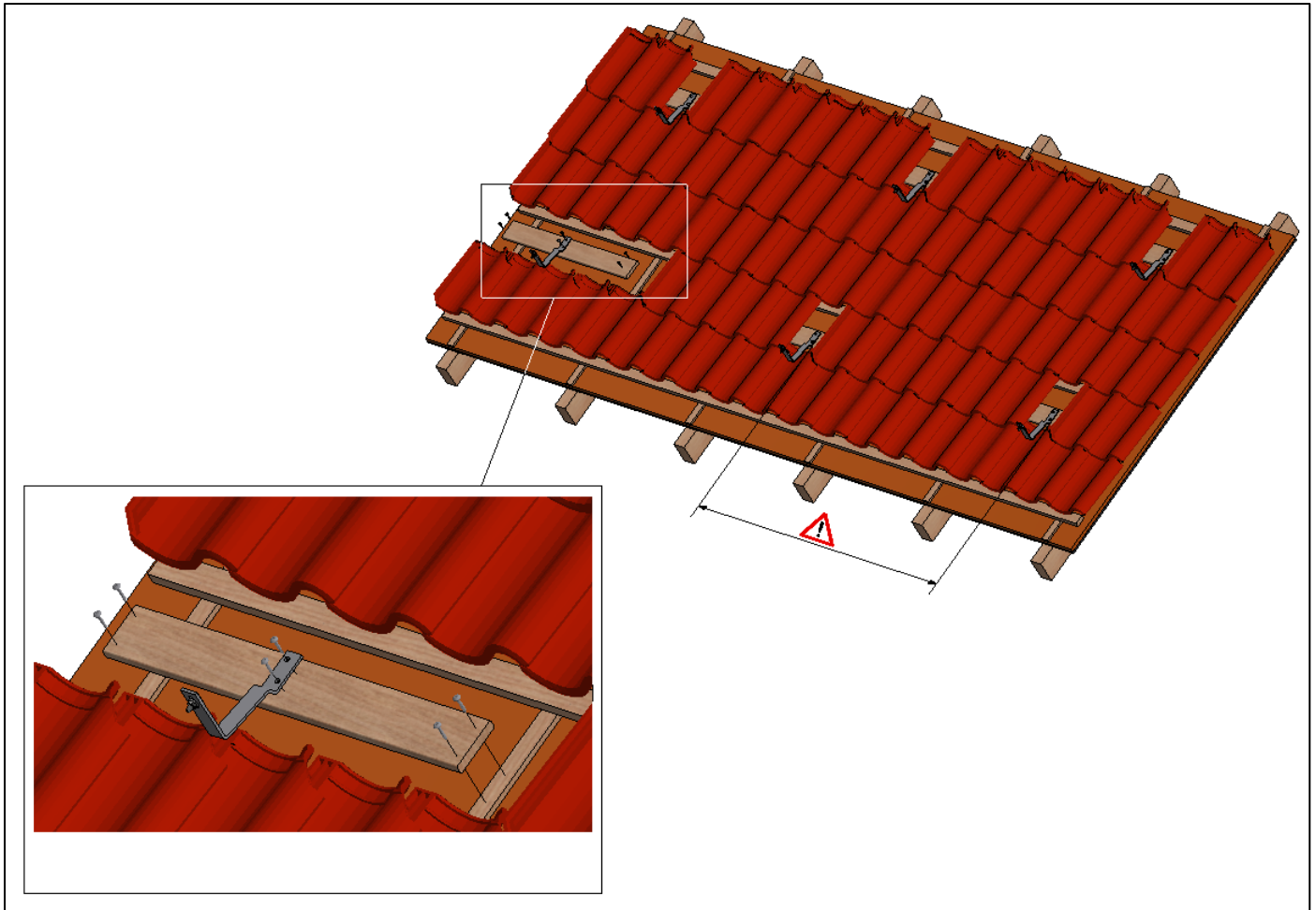

Check the outcome of the calculation for the maximum distance between the roof hooks and the required amount per profile.

It is important that the roof hooks have a 3mm clearance from the roof tile. If this is not the case the roof hook can be lifted by using the plastic yellow plates. (see image below)

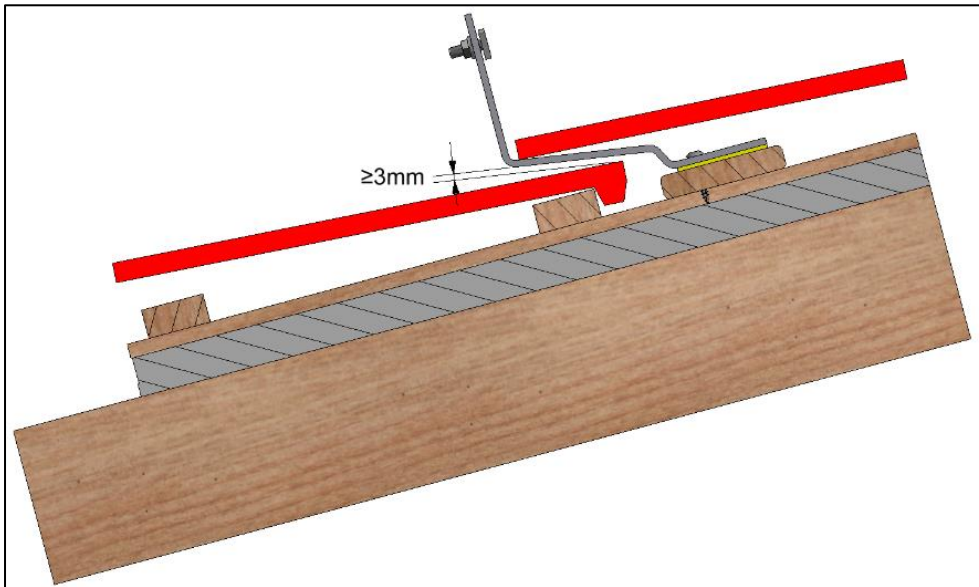

The yellow plates can be used to elevate the roof hook to the correct height. The two holes in the yellow plates can be aligned to the holes in the roof hook.

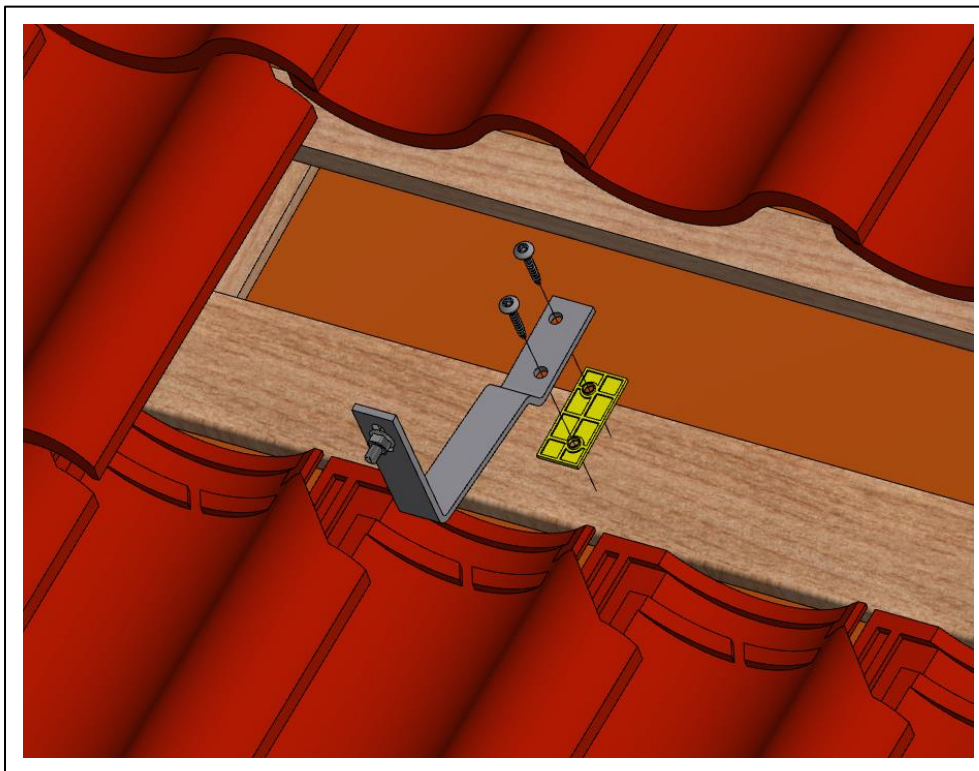

Mounting Slimline roof hook

The Slimline roof hooks are placed over the roof tile and its battens. When using the adjustable hooks make sure the roof hook is set to the correct height (see image next page). Make sure the roof hook are aligned properly so the profile can be mounted correct at all times.

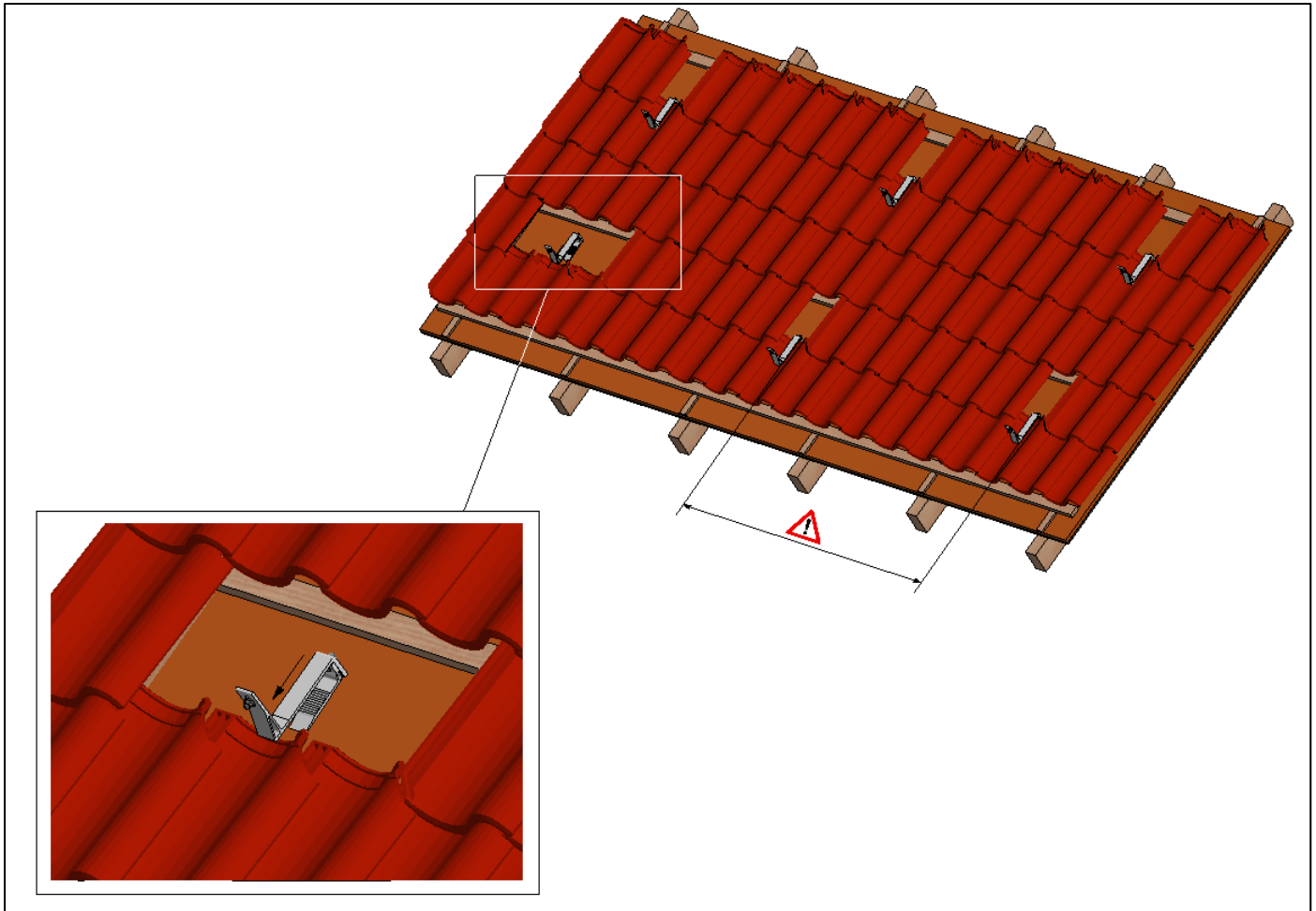

Check the outcome of the calculation for the maximum distance between the roof hooks and the required amount per profile.

The adjustable roof hook can be set changed to different dimensions. Make sure the roof hook cannot come of the battens easily, if it does lower the range of the roof hook.

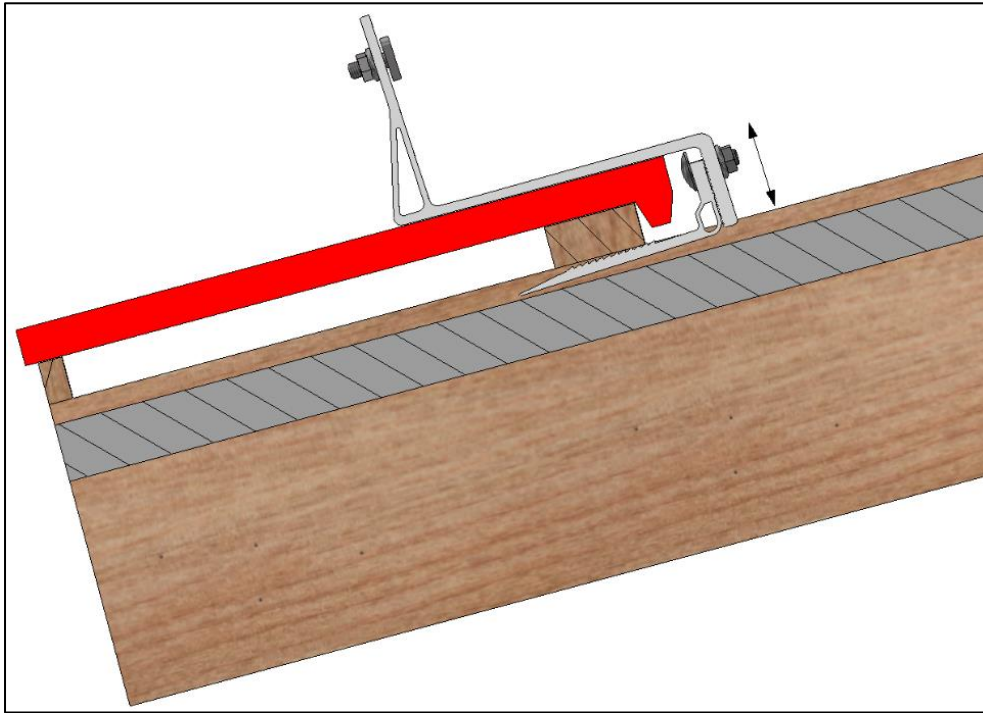

Mounting Strongline (Heavy Duty) roof hook

The Strongline roof hook is mounted on the purlins of the roof. Use the multiple holes of the mounting plate and the adjustable position of the hook to place the hook in the correct location. The Strongline roof hook must at least be fixed with 2 screws. The mounting of the Heavy Duty roof hook is the same as the standard Strongline roof hook.

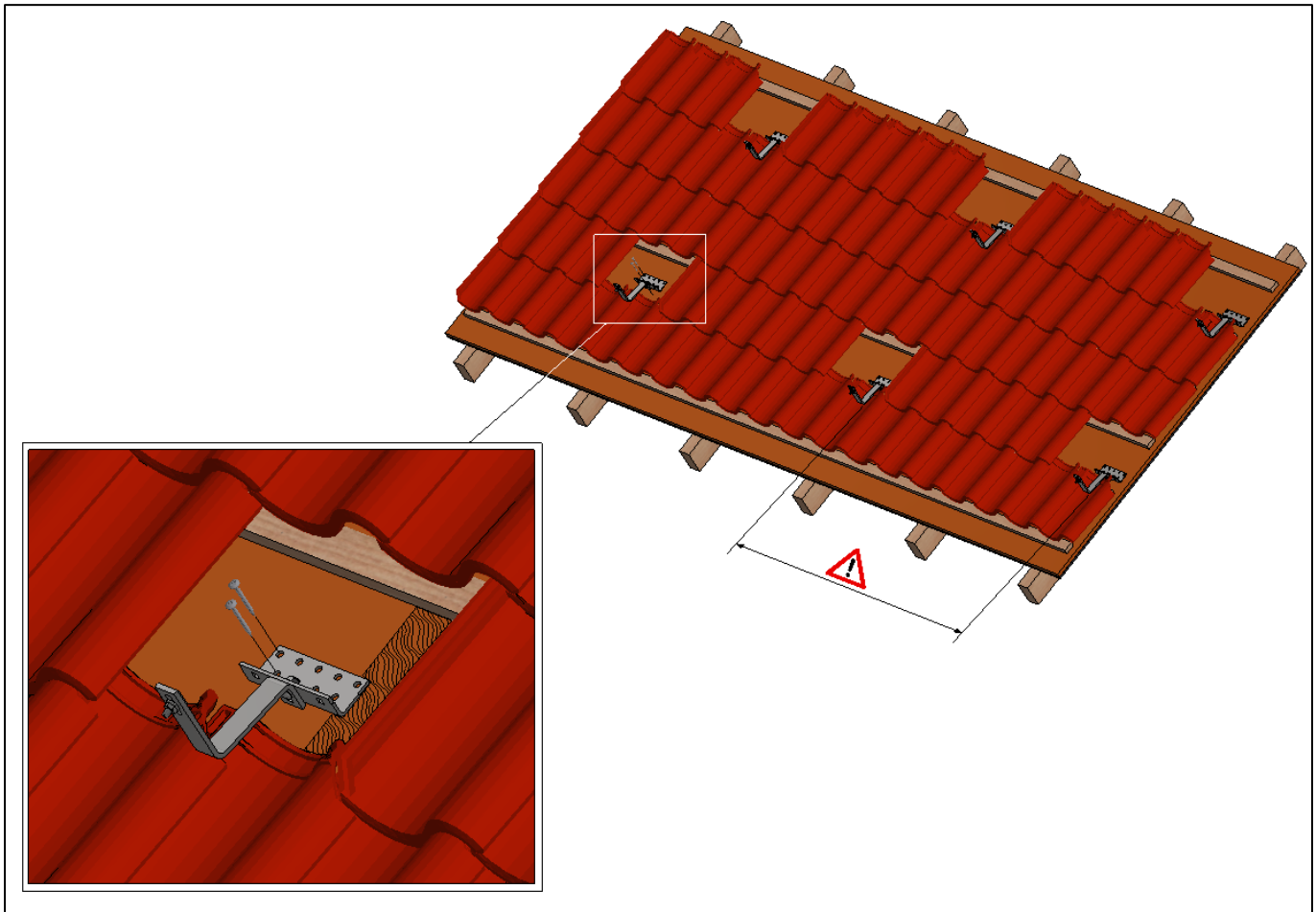

Check the outcome of the calculation for the maximum distance between the roof hooks and the required amount per profile.

It is important that the roof hooks have a 3mm clearance from the roof tile. This prevents the roof tile from breaking. (see image below)

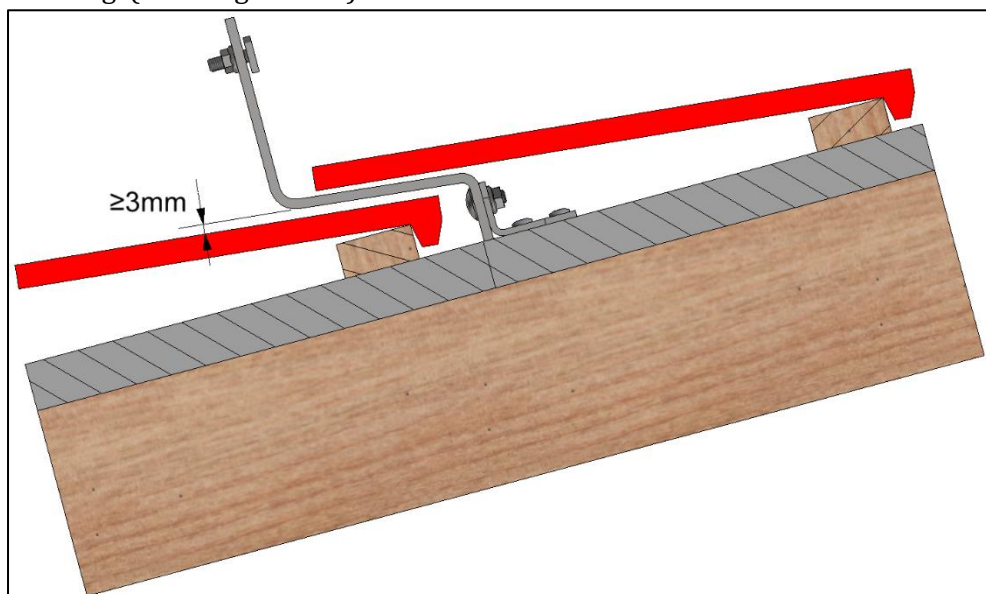

Mounting aluminium profiles

The mounting of the aluminium profiles is for all roof hooks the same. For the rest of the manual the Smartline roof hook will be shown, the workflow when using a different hook will remain the same.

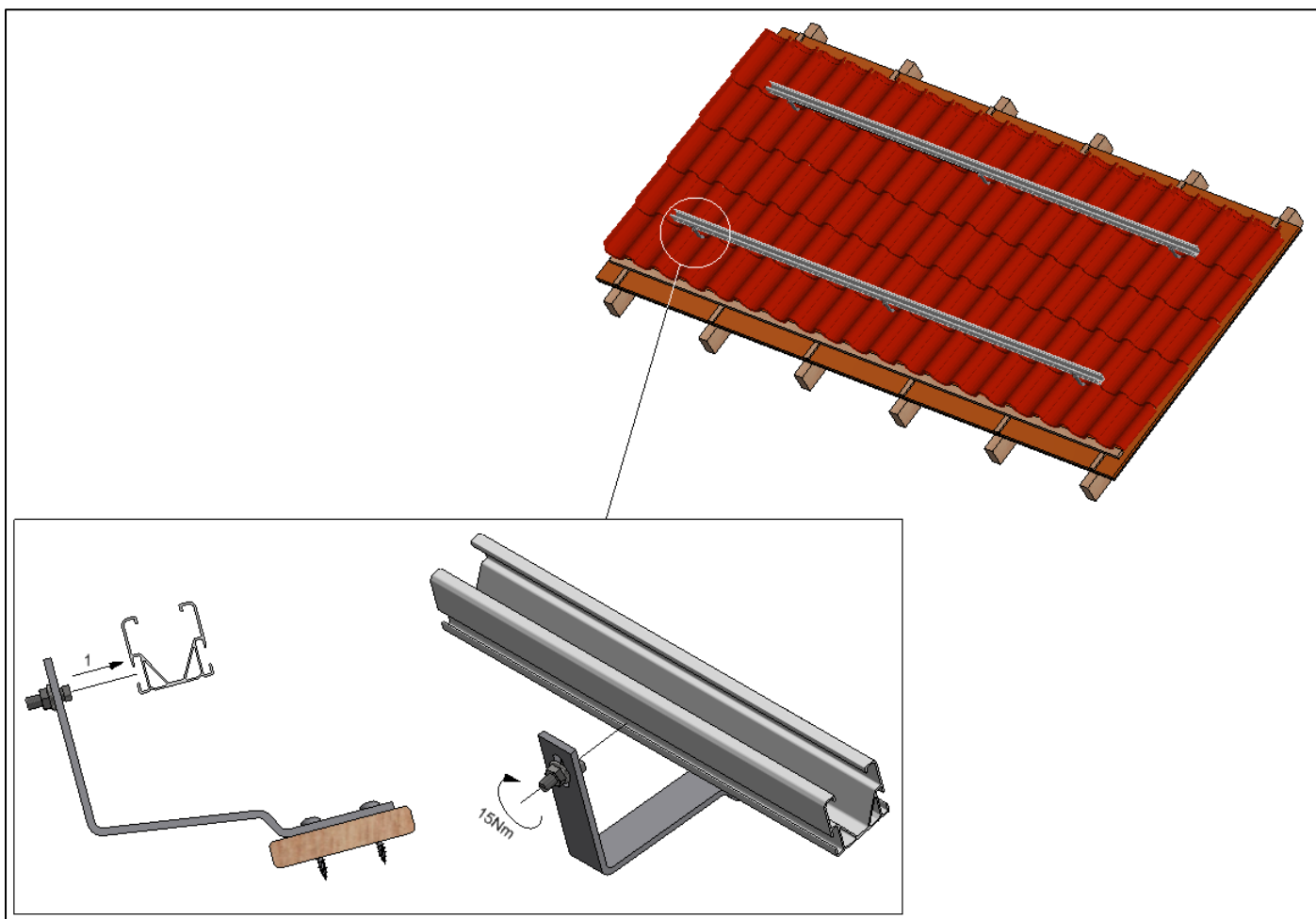

The aluminium profiles are mounted to the roof hooks with the hammerhead bolts. The hammerhead bolts are placed in the slots of the profiles. When all bolts are placed in the profile everything is fastened with the nut of the roof hook. (max. torque is 15Nm).

When fastening the bolt/nut of the roof hook it is important that the hammerhead bolt is correctly placed in the aluminium profile. If the hammerhead bolt is not in the profile properly the aluminium profile can come loose (see image below).

Dilatations

The coupled system has to be dilatated after certain measurements, this needs to be done because of the thermal expansion/contraction. For the aluminium profiles this measurement is 30 meters.

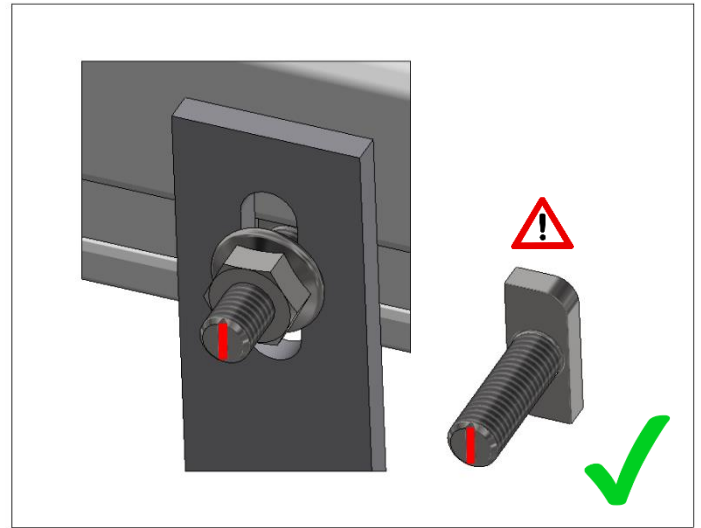
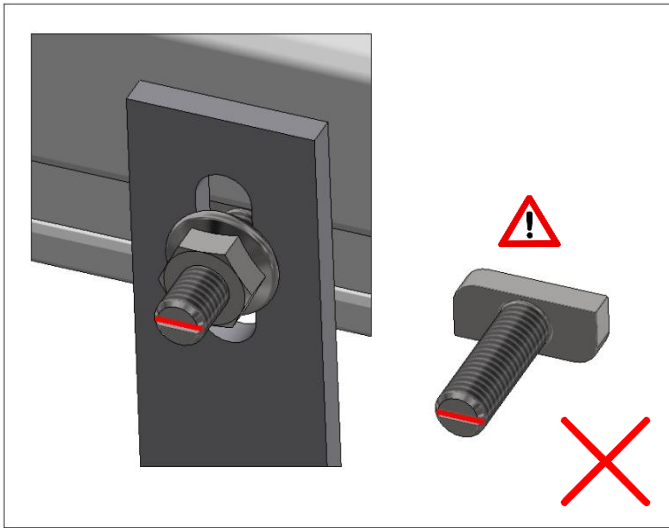

The groove on the hammerhead bolt corresponds with the orientation of the bolt head. Make sure the bolt is always mounted correctly.

Coupling aluminium profiles

The aluminium profiles can be coupled together with the coupling pieces (724863). Each coupling piece has 4 hammerhead bolts, 2 for each end of the profile. Make sure all hammerhead bolts are in the profiles and fix the lock nuts when ready. (max. torque is 15 Nm)

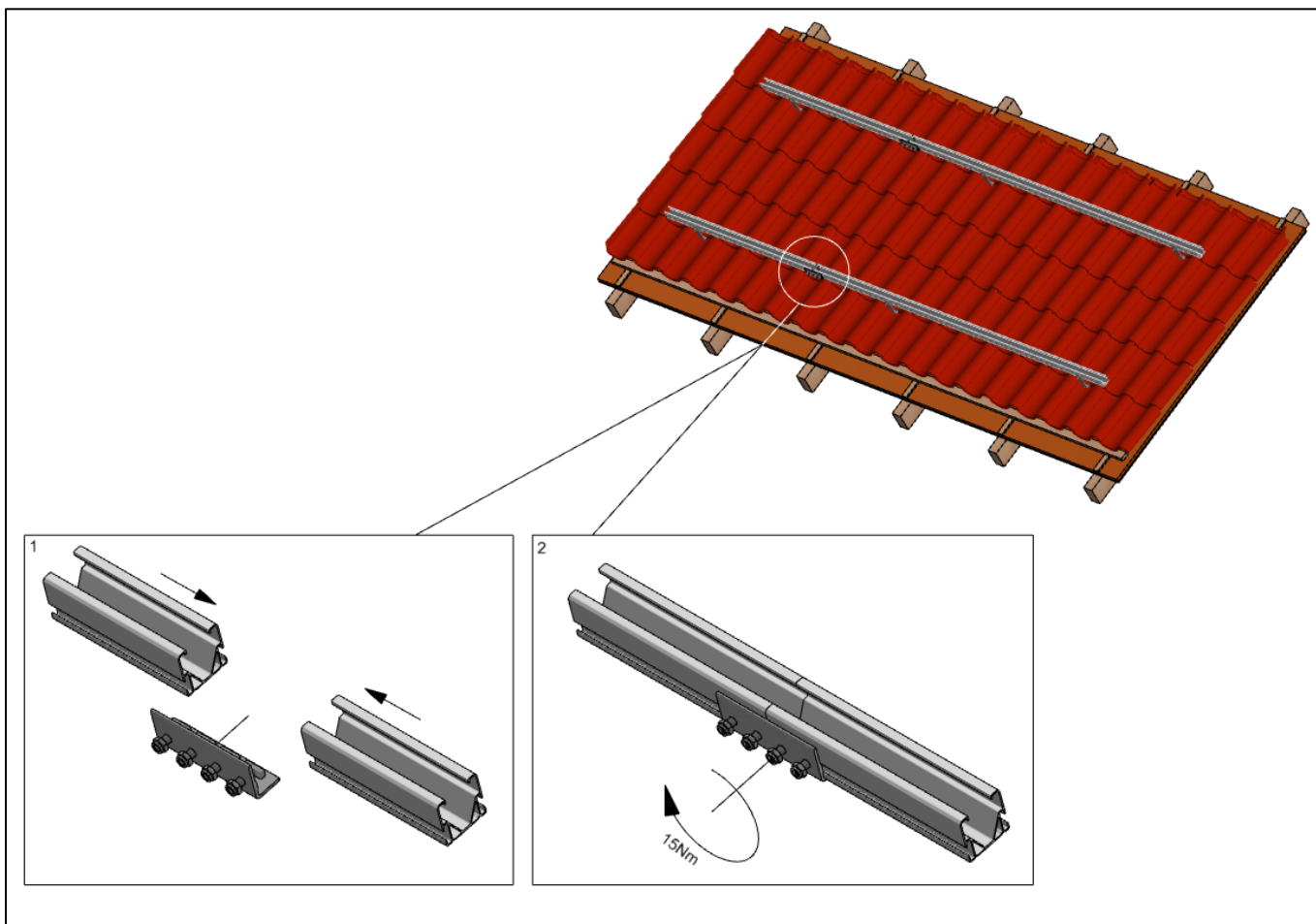

When fastening the bolt/nut of the coupling it is important that the hammerhead bolts are correctly placed in the aluminium profile. If the hammerhead bolts are not in the profile properly the aluminium profile can come loose (see image below).

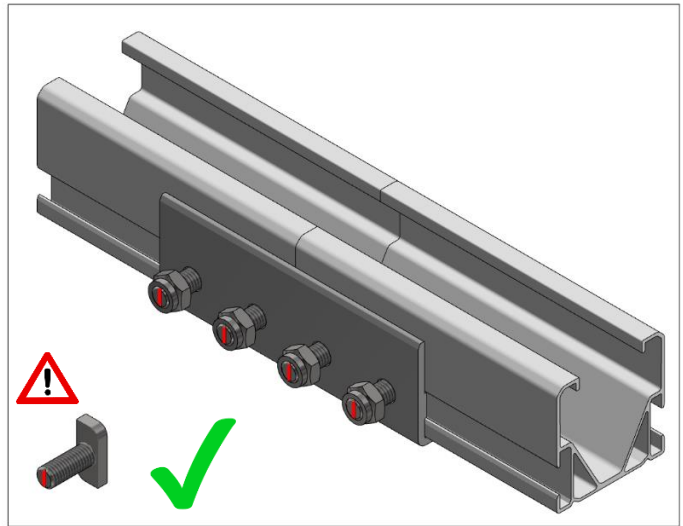
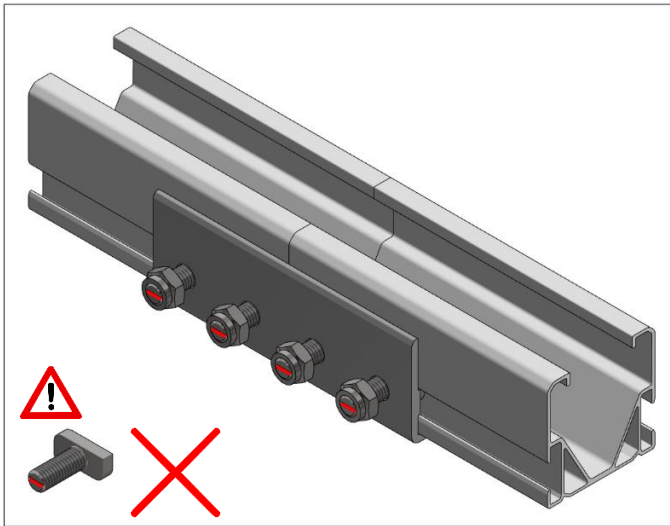

The groove on the hammerhead bolt corresponds with the orientation of the bolt head. Make sure the bolt is always mounted correctly.

Mounting end clamps

Each end of the panel row is fixed with the end clamps (721552). The end clamps have a range for the panel thickness from 28-50 mm.

The panel clamp can be mounted by turning it clockwise in the aluminium profile.

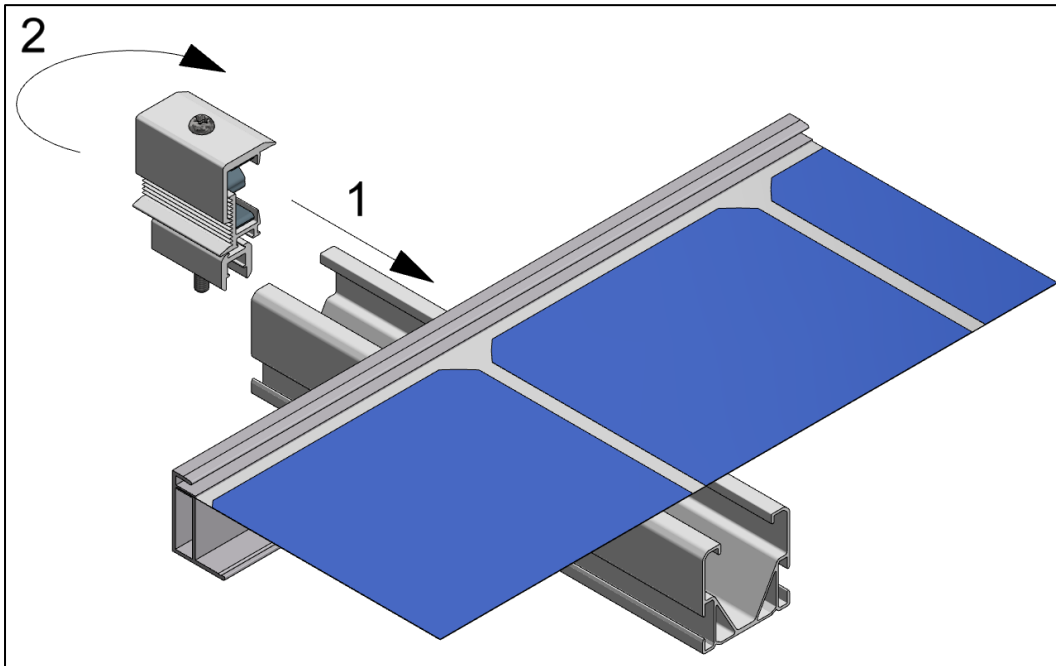

Once the end clamp is in the profile set the end clamp to the correct height. This is done by putting the top cap into one of the slots. (see below)

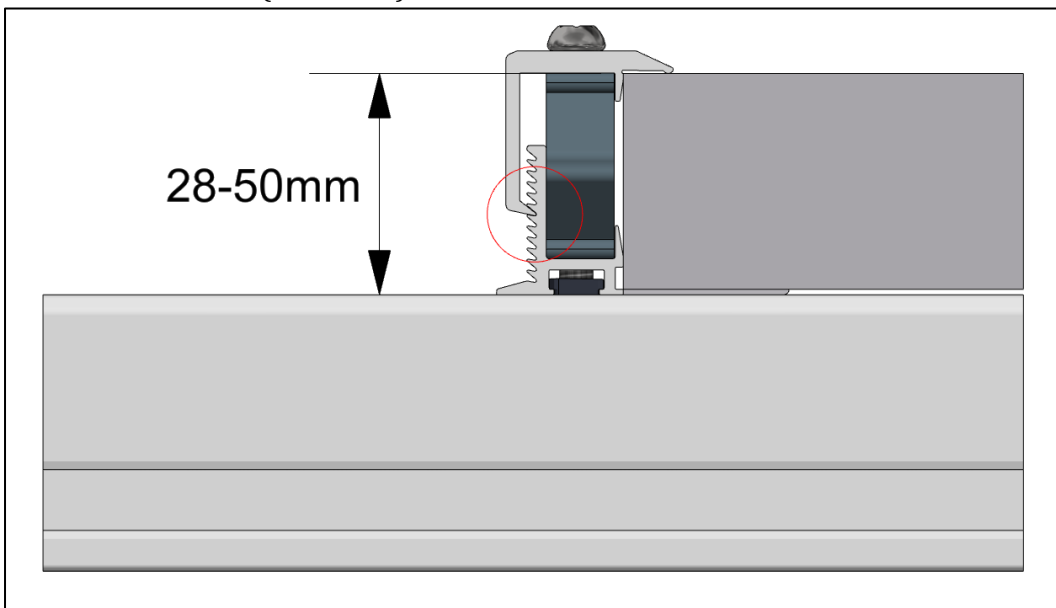

Use the bolt on top of the clamp to fix the end clamp. (torque 6-7 Nm)

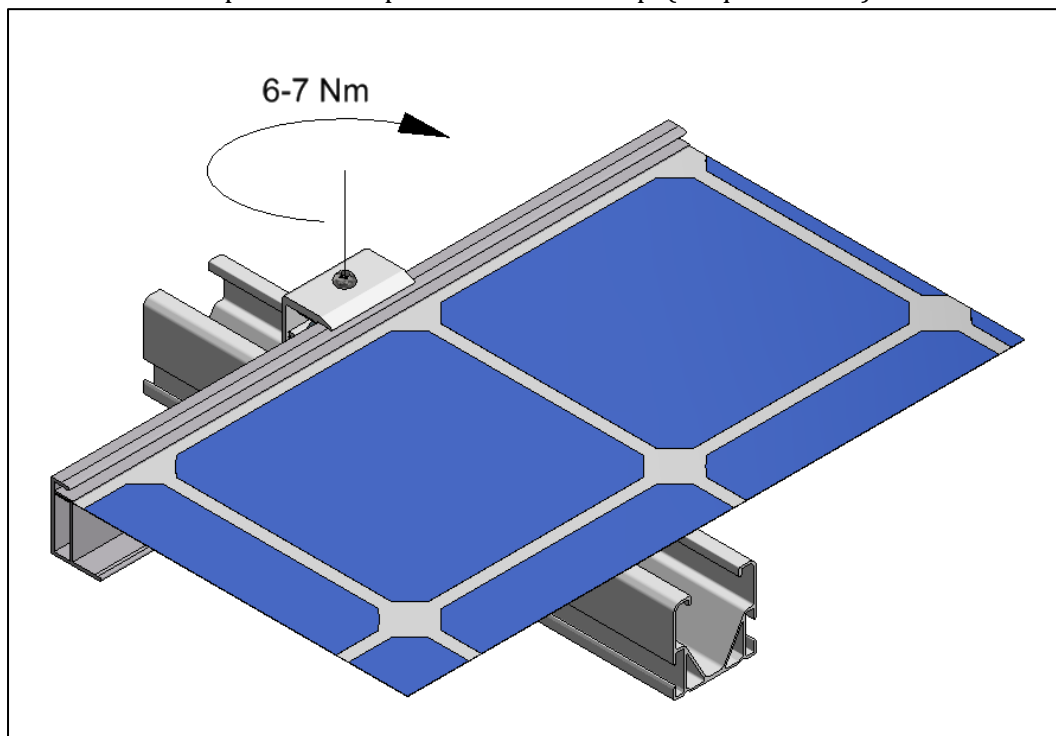

Mounting panel clamps (middle)

The middle clamps are mounted the same as the end clamp, only the height of the clamp is not set to a certain height.

Place the middle clamps in the profile and make sure the panels are pushed together. The panels have to be placed against the middle clamps until they can't go further.

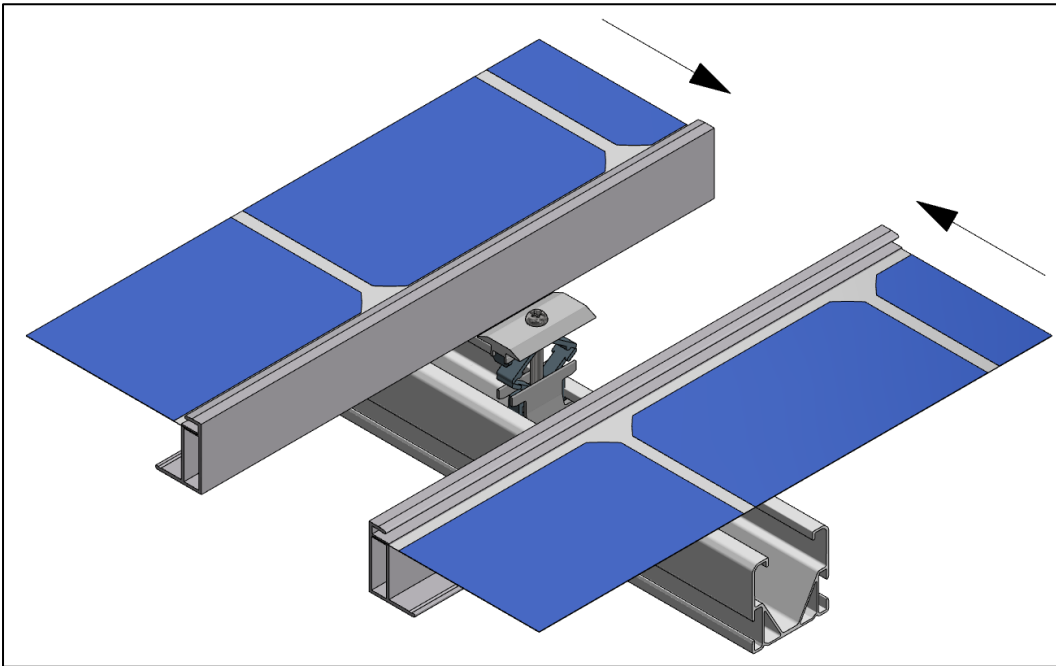

Once the panels and middle clamps are in place they can be fixed with the bolt of the middle clamp. (torque 6-7 Nm)

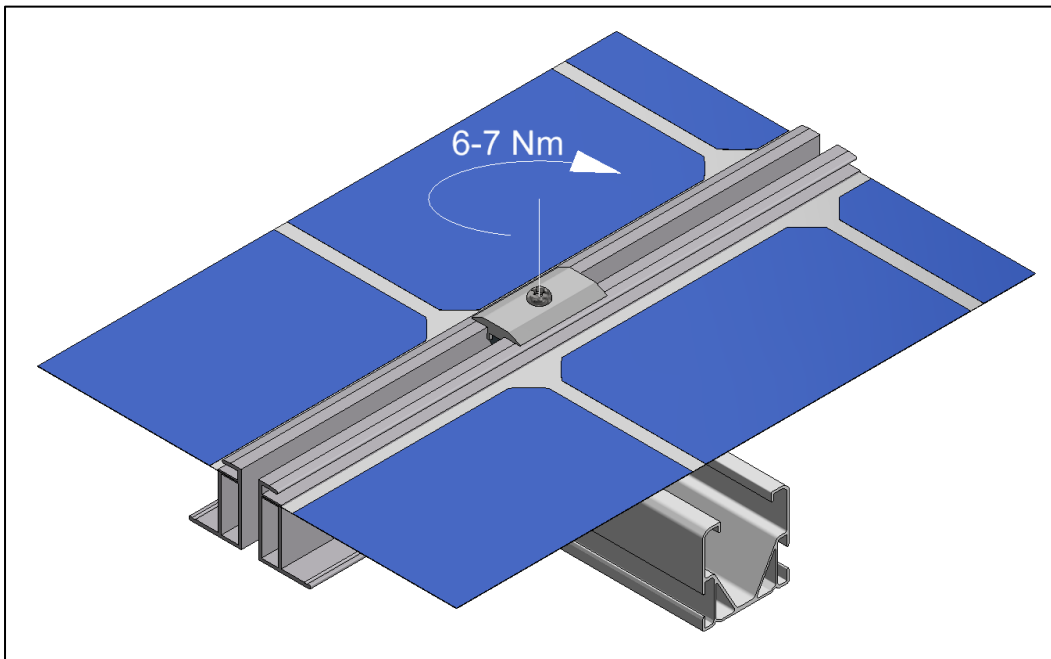

Cable clamps

For the pitched roof clamp systems there are 2 types of cable clamps available (standard). These cable clamps can be helpful with your cable management.

Small cable clamp (732001)

The small cable clamp can be mounted to the aluminium profile or the solar panel. The small cable clamp can fit 1 cable.

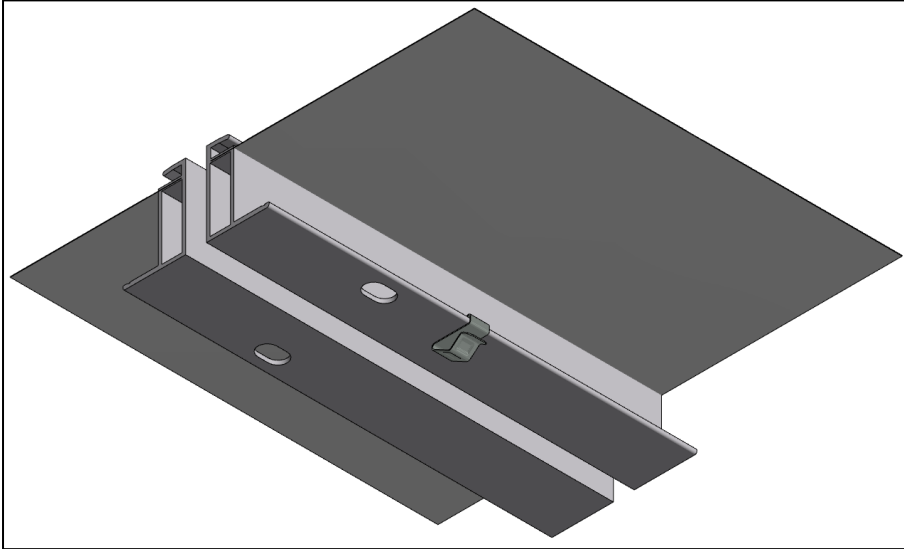

Cable clamp to panel frame

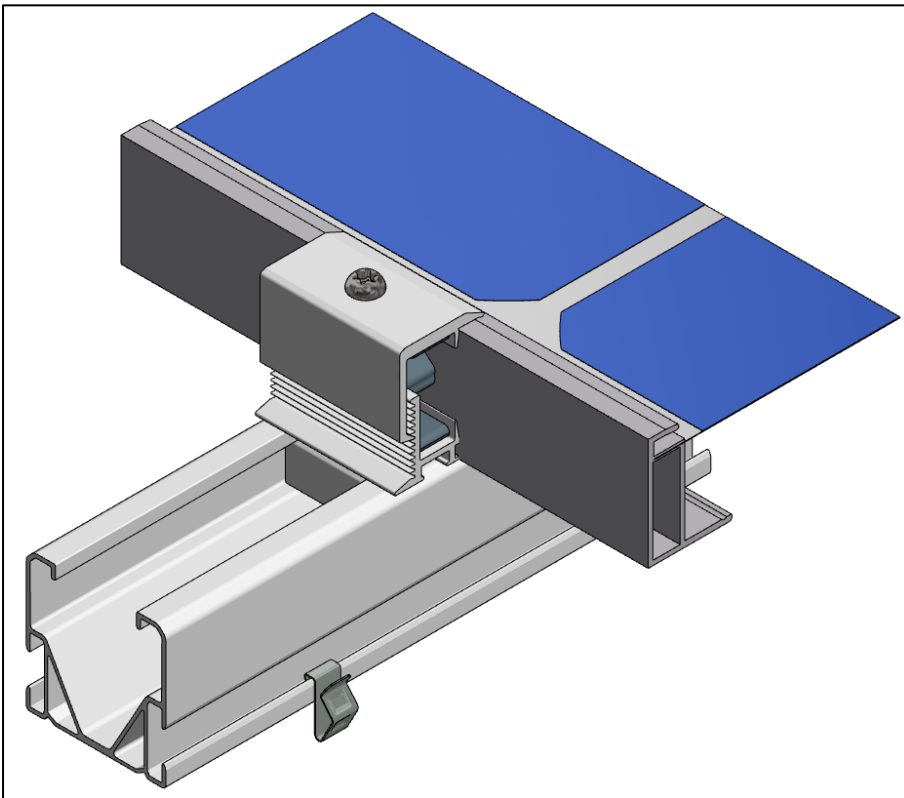

Cable clamp to aluminium profile

Large cable clamp (732005)

The large cable clamp can be placed on the aluminium profile. The larger cable clamp can hold multiple cables depending on the size.

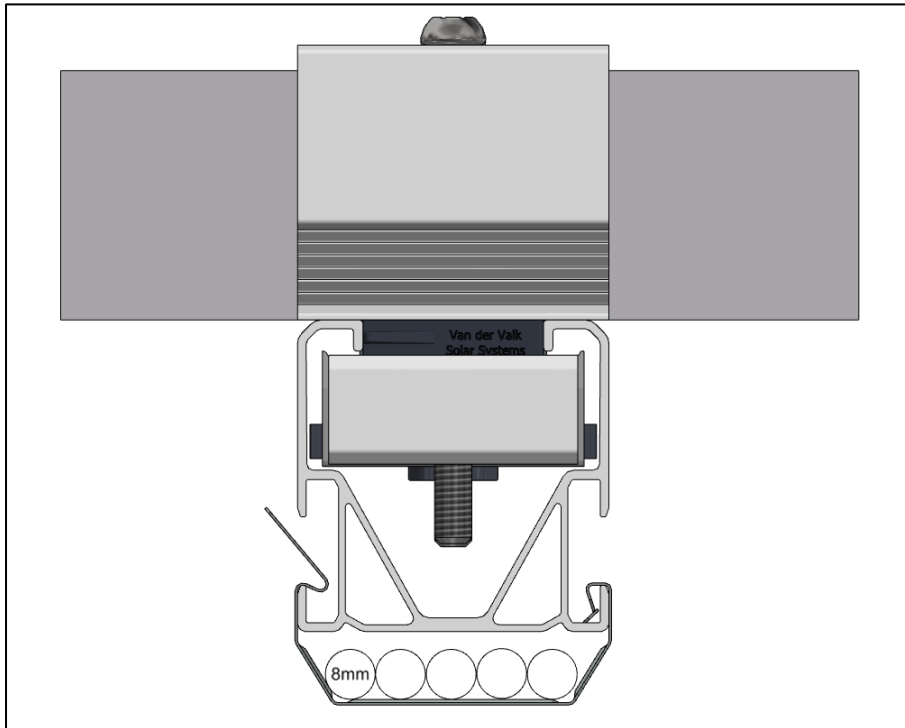

Mounting optional products

The pitched roof system has a variety of optional products that can be used to optimize the system. Down below is explained what each product does and how it should be mounted.

Black end cap (739052)

The black end cap is used in the 'semi-black' or 'full-black' systems. The end caps are placed over the aluminium profiles. This gives the system a better appearance overall.

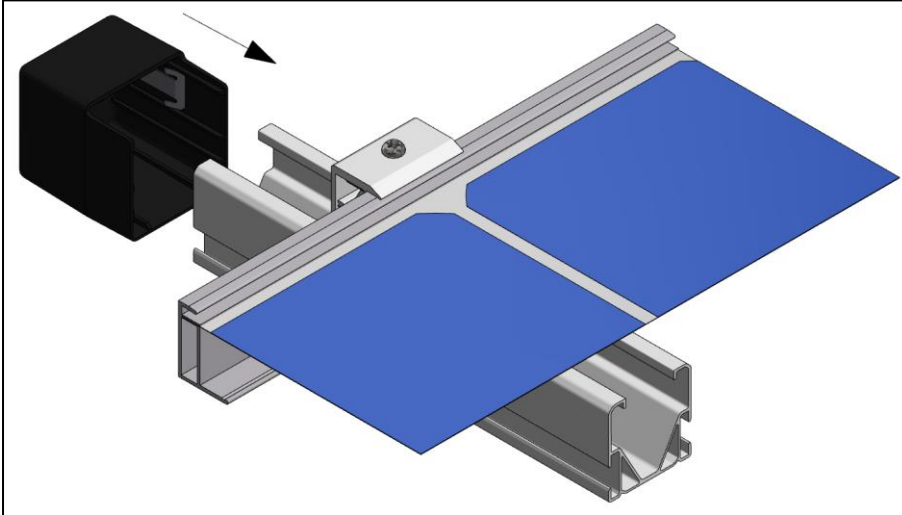

Micro inverter clamp (774223)

The micro inverter clamp is used to fix the micro inverter to the aluminium profile.

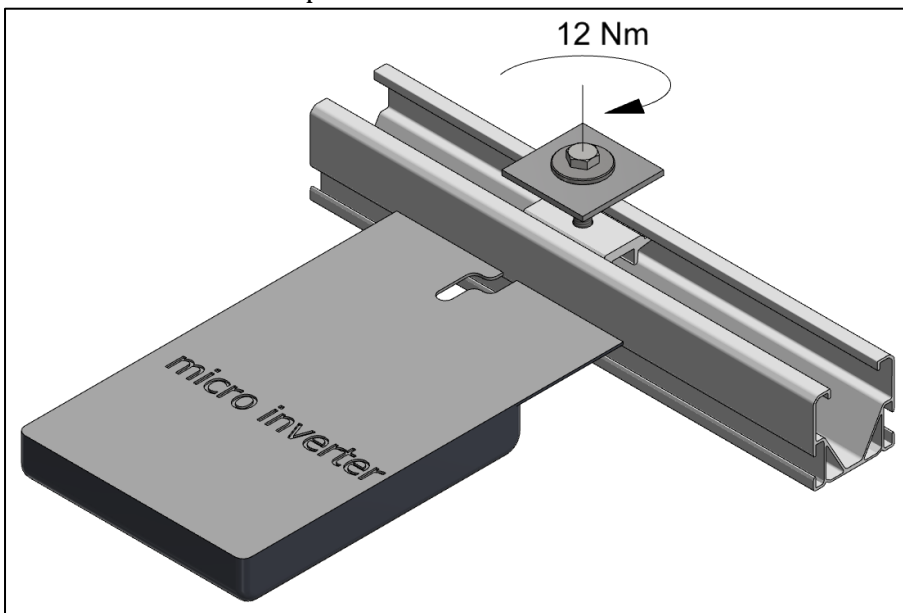

Panel alignment pin (733020)

The panel alignment pins can be mounted to the frame of the solar panel. Once the pins are fixed to the frame the panel can easily be hung to the aluminium profile. This gives the option to mount the panel clamps without being bothered by the alignment of the panel.

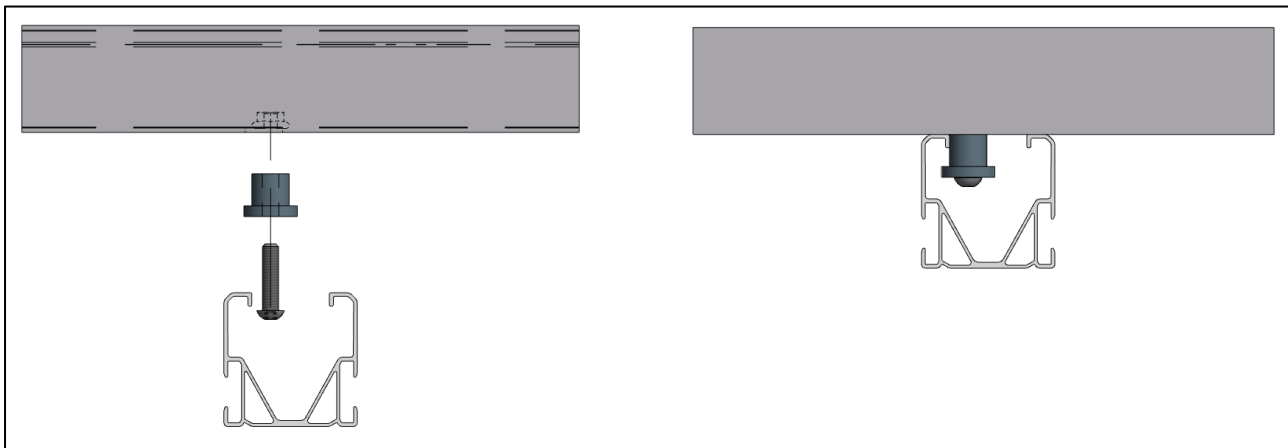

Clamp covers

In case solar panels with a black frame are used, plastic clamp covers can be used for a complete black finish of the system.

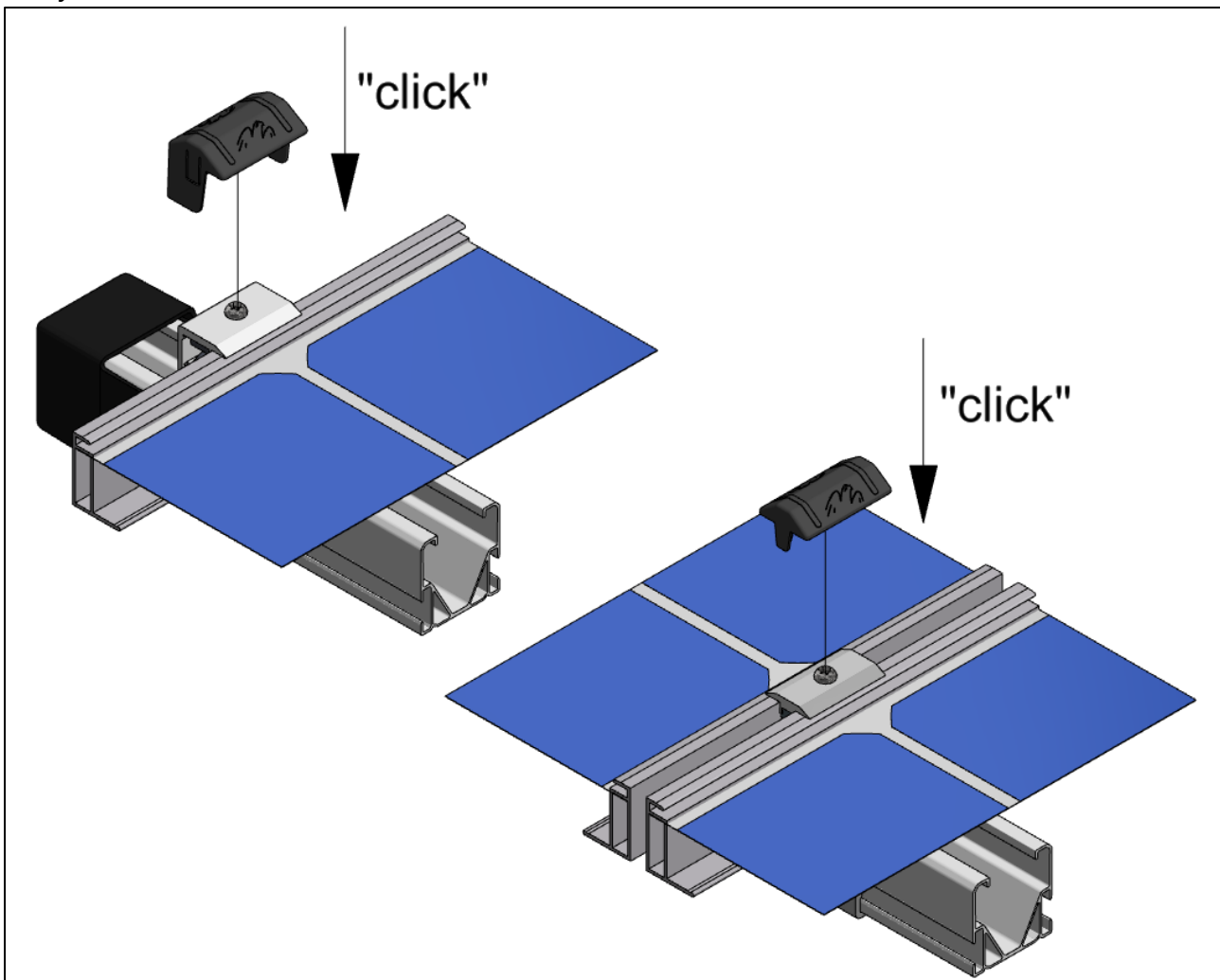

Van der Valk Solar Systems

Van der Valk Solar Systems is since 2009 one of the fastest growing companies in the solar industry and focuses entirely on the development and production of solar mounting systems for pitched roofs, flat roofs and open fields. Van der Valk Solar Systems also has an office and warehouse in the UK, offices in Sweden and Spain and is currently active in 13 countries.

Our mounting systems are developed and produced in our own factory in the Netherlands and stand out thanks to their broad area of application, the very short time in which they can be installed, and the high quality. They are developed according to the latest Eurocodes and therefore comply with the requirements defined for solar systems by banks and insurance companies.

Van der Valk Solar Systems is part of family-owned company Van der Valk Systemen, which has been a household name in the field of moving systems and mounting components since 1963.

Our shared industrial complex consists of 20,000m² of offices and factory spaces. Here we use modern machinery and the latest technologies to quickly and accurately develop, manufacture, and test products and systems.



Solar mounting systems & cable management



Flat roofs



Pitched roofs



Ground mount



Cable management

CONTACT DETAILS | DEVELOPER AND PRODUCER OF SOLAR MOUNTING SYSTEMS



Van der Valk Solar Systems + International
Westernesse 18 - 2635 BG Den Hoorn, The Netherlands
+31 174 25 49 99
sales@valksolarsystems.com

Valk Solar Systems UK + IE
+44 1304 89 76 58
sales@valksolarsystems.co.uk

Valk Solar Systems Ibérica
+34 699 326 544
ventas@valksolarsystems.es

Valk Solar Systems Nordics
+46 7 24 41 60 82
sales@valksolarsystems.se

www.valksolarsystems.com