



X3-FORTH SERIES USER MANUAL

40kW - 150kW



SolaX Power Network Technology (Zhe jiang) Co., Ltd.

NO.288 Shizhu Road, Tonglu Economic Development Zone, Tonglu City, Zhejiang province, China.

Tel: +86 0571-56260011

E-mail: info@solaxpower.com

614.00663.02

EN

Copyright Declaration

The copyright of this manual belongs to Solax Power Network Technology (Zhe jiang) Co., Ltd. Any corporation or individual should not plagiarize, partially or fully copy (including software, etc.) , and no reproduction or distribution of it in any form or by any means. All rights reserved. SolaX Power Network Technology (Zhe jiang) Co., Ltd. reserves the right of final interpretation.

www.solax.power.com

CONTENTS

1	NOTE ON THIS MANUAL.....	03
1.1	SCOPE OF VALIDITY.....	03
1.2	TARGET GROUP.....	03
1.3	SYMBOLS USED.....	03
2	SAFETY.....	04
2.1	APPROPRIATE USAGE.....	04
2.2	IMPORTANT SAFETY INSTRUCTIONS.....	05
2.3	EXPLANATION OF SYMBOLS.....	08
2.4	EC DIRECTIVES.....	10
3	INTRODUCTION.....	11
3.1	PHOTOVOLTAIC GRID CONNECTED SYSTEM.....	11
3.2	BASIC FEATURES.....	13
3.3	OVERVIEW OF THE INVERTER.....	13
3.4	DIMENSION	14
3.5	PRINCIPLE DESCRIPTION.....	15
4	TECHNICAL DATA.....	16
4.1	DC INPUT.....	16
4.2	AC OUTPUT.....	17
4.3	EFFICIENCY, SAFETY AND PROTECTION.....	18
4.4	GENERAL DATA	19
5	MECHANICAL INSTALLATION.....	20
5.1	INSTALLATION PRECAUTION.....	20
5.2	SELECTION FOR THE INSTALLATION POSITION.....	20
5.2.1	INSTALLATION ENVIRONMENT REQUIRED.....	21
5.2.2	INSTALLATION CARRIER REQUIRED.....	21
5.2.3	INSTALLATION ANGLE REQUIRED.....	22
5.2.4	INSTALLATION SPACE REQUIRED.....	23
5.3	TOOLS PREPARATION.....	24
5.4	CHECK FOR TRANSPORT DAMAGE	25
5.5	PACKING LISTS.....	25

5.6 INSTALLATION STEPS.....26

 5.6.1 INSTALLATION STEPS (ON THE WALL)26

 5.6.2 INSTALLATION STEPS (ON THE STAND).....27

6 ELECTRICAL CONNECTION.....29

6.1 GROUNDING CONNECTION.....29

6.2 PV STRING CONNECTION.....30

6.3 GRID CONNECTION.....33

6.4 COMMUNICATION CONNECTION.....36

 6.4.1 COMMUNICATION SIGNAL DEFINITION.....36

 6.4.2 CONNECTION STEPS OF CABLE.....37

 6.4.3 RELEASE STEPS OF CABLE.....38

6.5 MONITORING CONNECTION.....39

7 STARTUP OF THE INVERTER.....41

8 TROUBLESHOOTING.....43

 8.1 TROUBLESHOOTING.....43

 8.2 ROUTINE MAINTENANCE.....48

9 DECOMMISSIONING.....50

 9.1 DISMANTLING THE INVERTER.....50

 9.2 PACKAGING.....50

 9.3 STORAGE AND TRANSPORTATION.....50

 9.4 DISPOSING OF THE X3-FORTH.....50

10 DISCLAIMER51

* WARRANTY REGISTRATION FORM

1 Notes on this Manual

1.1 Scope of Validity

This manual is an integral part of X3-Forth Series, It describes the assembly, installation, commissioning, maintenance and failure of the product. Read it carefully before operating.

X3-FTH-40K-LV	X3-FTH-50K-LV	X3-FTH-60K-LV	X3-FTH-70K-LV
X3-FTH-80K	X3-FTH-100K	X3-FTH-110K	X3-FTH-120K
X3-FTH-125K	X3-FTH-136K-MV	X3-FTH-150K-MV	





Note: “X3”: means three phases, “FTH” means Forth, “80K” means 80 kW. Each model is available with LED indicator lights and LCD.
 40K/50K/60K/70K inverters works in the 220 V / 127 V low voltage range.
 80K/100K/110K/120K/125K inverters works in the 220 V / 380 V voltage range.
 136K/150K inverters works in the 500 V / 540 V medium voltage range.
 Keep this manual at the place where it is accessible all the time.

1.2 Target Group

This manual is for qualified electricians. The tasks described in this manual only can be performed by qualified electricians.

1.3 Symbols Used

The following types of safety instructions and general information appear in this document as described below:

	DANGER! “Danger” indicates a hazardous situation which, if not avoided, will result in death or serious injury.
	WARNING! “Warning” indicates a hazardous situation which, if not avoided, could result in death or serious injury.
	CAUTION! “Caution” indicates a hazardous situation which, if not avoided, could result in minor or moderate injury.
	NOTE! “Note” provides tips that are valuable for the optimal operation of your product.

2 Safety

2.1 Appropriate Usage

The X3-Forth Series are PV inverters which can convert the DC current of the PV generator into AC current and feed it into the public grid.

Surge protection devices (SPDs) for PV installation



WARNING!

- Over-voltage protection with surge arresters should be provided when the PV power system is installed.
- The grid connected inverter is fitted with SPDs in MAINS side.

Induced surges are the more likely cause of lightning damage in the majority of installations, especially in rural areas where electricity is usually provided by long overhead lines. Surges may be induced on both the PV array conductors or the AC cables leading to the building.

Specialists in lightning protection should be consulted in the actual application. Using appropriate external lightning protection, the effect of a direct lightning

Installation of SPDs to protect the inverter against mechanical damage and excessive stress include a surge arrester in case of a building with external lightning protection system (LPS) when separation distance is kept.

To protect the DC system, surge protection device (SPD type2) should be fitted at the inverter end of the DC cabling and at the array located between the inverter and the PV generator, if the voltage protection level (VP) of the surge arresters is greater than 1100V, an additional SPD type 3 required for surge protection for electrical devices.

To protect the AC system, surge protection devices (SPD type2) should be fitted at the main incoming point of AC supply (at the consumer's cutout) , located between the inverter and the meter / distribution system; SPD (test impulse D1) for signal line according to EN 61632-1.

All DC cables should be installed to provide as short a run as possible, and positive and negative cables of the string or main DC supply should be bundled together. Avoid creating loops in the system. This requirement for short runs and bundling includes any associated earth bundling conductors.

Spark gap protection devices are not suitable to be used in DC circuits once conducting, they won't stop conducting until the voltage passes through their terminals typically less than 30 volts.

- **Anti-Islanding Effect**

Islanding effect is a special phenomenon that grid-connected PV system still supplies power to the nearby grid when electrical grid power is no longer present. It is dangerous for maintenance personnel and the public. X3-Forth series provide Active Frequency Drift (AFD) to prevent islanding effect.

2.2 Important Safety Instructions



DANGER!
Danger to life due to high voltages in the inverter!

- All work must be carried out by qualified electrician.
- The appliance is not to be used by children or persons with reduced physical sensory or mental capabilities, or lack of experience and knowledge, unless they have been given supervision or instruction.
- Children should be supervised to ensure that they do not play with the appliance.



CAUTION!

- Danger of burn injuries due to hot enclosure parts!
- During operation, the upper lid of the enclosure and the enclosure body may become hot.
- Only touch the lower enclosure lid during operation.



CAUTION!

- Possible damage to health as a result of the effects of radiation!
- Do not stay closer than 20 cm to inverter for any length of time.



NOTE!

Grounding the PV generator.

- Comply with the local requirements for grounding the PV modules and the PV generator. SolaX recommends connecting the generator frame and other electrically conductive surfaces in a manner which ensures continuous conduction and ground these in order to have optimal protection of system and persons.

**WARNING!**

- Ensure input DC voltage \leq Max. DC voltage .Over voltage may cause permanent damage to inverter or other losses, which will not be included in warranty!

**WARNING!**

- Authorized service personnel must disconnect both AC and DC power from X3-Forth series before attempting any maintenance or cleaning or working on any circuits connected to the X3 series.

**WARNING!**

- Do not operate the inverter when the device is running.

**WARNING!**

- Risk of electric shock!

- Prior to the application, please read this section carefully to ensure correct and safe application. Please keep the user manual properly.
- Use only attachments recommended or sold by SolaX. Otherwise may result in a risk of fire, electric shock, or injury to person.
- Make sure that existing wiring is in good condition and that wire is not undersized.
- Do not disassemble any parts of inverter which are not mentioned in installation guide. It contains no user-serviceable parts. See Warranty for instructions on obtaining service. Attempting to service the X3 Series inverter yourself may result in a risk of electric shock or fire and will void your warranty.
- Keep away from flammable, explosive materials to avoid fire disaster.
- The installation place should be away from humid or corrosive substance.
- Authorized service personnel must use insulated tools when installing or working with this equipment.
- PV modules shall have an IEC 61730 class A rating.
- Never touch either the positive or negative pole of PV connecting device.
- Strictly prohibit touching both of them at the same time.
- The unit contains capacitors that remain charged to a potentially lethal voltage after the MAINS and PV supply has been disconnected.

**WARNING!**

- Hazardous voltage will present for up to 5 minutes after disconnection from power supply.

- CAUTION-RISK of electric shock from energy stored in capacitor. Never operate on the solar connectors, The MAINS cables, PV cables or the PV generator when power is applied. After switching off the PV and Mains, always wait for 5minutes to let the intermediate circuit capacitors discharge before you unplug DC and MAINS connectors.
- When accessing the internal circuit of solar inverter, it is very important to wait 5 minutes before operating the power circuit or demounting the electrolyte capacitors inside the device. Do not open the device beforehand since the capacitors require time to sufficiently discharge!

PE Connection and Leakage Current

- The inverter incorporates a certified internal Residual Current Device (RCD) in order to protect against possible electrocution and fire hazard in case of a malfunction in the cables or the inverter. There are two trip thresholds for the RCD as required for certification (IEC 62109-2: 2011) .
- The default value for electrocution protection is 30 mA, and for slow rising current is 300 mA.
- If an external RCD is required by local regulations, check which type of RCD is required for relevant electric code. It recommends using a type-A RCD. The recommended RCD values is 100 mA or 300 mA unless a lower value is required by the specific local electric codes. When required by local regulations, the use of an RCD type B is permitted.

The device is intended to connect to a PV generator with a capacitance limit of approx 700 nf.

**WARNING!**

- High leakage current!
- Earth connection essential before connecting supply.

- Incorrect grounding can cause physical injury, death or equipment malfunction and increase electromagnetic.
- Make sure that grounding conductor is adequately sized as required by safety regulations.
- Do not connect the ground terminals of the unit in series in case of a multiple installation. This product can cause current with a d.c component,
- Where a residual current operated protective (RCD) or monitoring (RCM) device is used for protection in case of direct or indirect contact, only one RCD or RCM of type B is allowed on the supply side of this product.

For United Kingdom

- The installation that connects the equipment to the supply terminals shall comply with the requirements of BS 7671.
- Electrical installation of PV system shall comply with requirements of BS 7671 and IEC 60364-7-712.
- No protection settings can be altered.
- Installer shall ensure that equipment is installed and operated to maintain at all times in compliance with the requirements of ESQCR22 (1) (a) .





For Australia and New Zealand

- Electrical installation and maintenance shall be conducted by licensed electrician and shall comply with Australia National Wiring Rules.



2.3 Explanation of Symbols







This section gives an explanation of all the symbols shown on the inverter and on the type label.

• Symbols on the Inverter

Symbol	Explanation
	Communication indicator
	DC connection indicator
	Grid connection indicator
	Alarm indicator

• Symbols on the Type Label

Symbol	Explanation
	CE mark. The inverter complies with the requirements of the applicable CE guidelines.
	TUV certified

	Beware of hot surface. The inverter can become hot during operation. Avoid contact during operation.
	Danger of high voltages. Danger to life due to high voltages in the inverter!
	Danger. Risk of electric shock!
	Observe enclosed documentation.
	The inverter can not be disposed together with the household waste. Disposal information can be found in the enclosed documentation.
	Do not operate this inverter until it is isolated from mains and on-site PV generation suppliers.
	Danger to life due to high voltage. There is residual voltage in the inverter which needs 5 minutes to discharge. • Wait 5 minutes before you open the upper lid or the DC lid.

2.4 EC Directives

This chapter follows the requirements of the European low voltage directives, which contains the safety instructions and conditions of acceptability for the end user system, which you must follow when installing, operating and servicing the unit. If ignored, physical injury or death may follow, or damage may occur to the unit. Read this instructions before you work on the unit. If you are unable to understand the dangers, warnings, cautions or instructions, contact an authorized service dealer before installing. Operating and servicing the unit.

The Grid connected inverter meets the requirement stipulated in Low Voltage Directive (LVD) 2014/35/EU and Electromagnetic Compatibility (EMC) Directive 2014/30/EU. The unit is based on:

EN 62109-1:2010; EN 62109-2:2011; IEC 62109-1 (ed.1); IEC62109-2 (ed.1); EN 61000-6-3:2007+A:2011; EN 61000-6-1:2007; EN 61000-6-2:2005

In case of installation in PV system, startup of the unit (i.e. start of designated operation) is prohibited until it is determined that the full system meets the requirements stipulated in EC Directive (2014/35/EU, 2014/30/EU, etc.)

The grid connected inverter leave the factory completely connecting device and ready for connection to the mains and PV supply, the unit shall be installed in accordance with national wiring regulations. Compliance with safety regulations depends upon installing and configuring system correctly, including using the specified wires. The system must be installed only by professional installers who are familiar with requirements for safety and EMC. The installer is responsible for ensuring that the end system complies with all the relevant laws in the country where it is to be used.

The individual subassembly of the system shall be interconnected by means of the wiring methods outlined in national / international such as the national electric code (NFPA) No.70 or VDE regulation 0107.

3. Introduction

3.1 Photovoltaic grid connected system

X3-Forth, a three-phase transformerless grid connected inverter, is an important part of photovoltaic power generation system. It converts the direct current generated by the photovoltaic panel into alternating current and also can be used to optimize self-consumption or feed into the public grid. The first figure shows the typical application scenario of 40k-125k inverter and the second figure shows the typical application scenario of 136k-150k inverter.

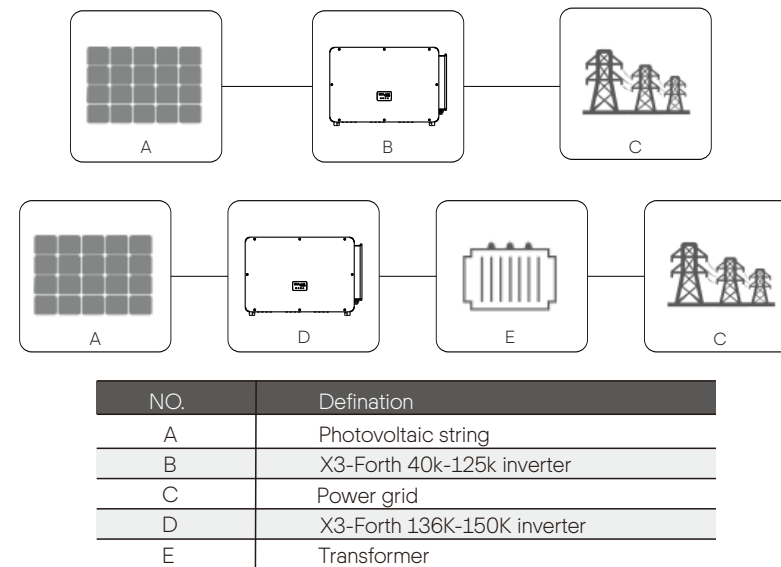

Warning!

- The inverter shall not be connected to the PV string requiring positive grounding or negative grounding. Do not connect local load between inverter and AC side circuit breaker!

The power grid supported by X3-Forth inverter are TN-S, TN-C, TN-C-S, TT and IT.

40 kW-70 kW inverters are connected to 220 V / 127 V three-phase four wire power grid and 80 kW-120 kW inverters are connected to 380V / 400V three-phase four wire power grid, which must be connected with N line (or not), as shown in Figure 1;

136 kW and 150 kW models are directly connected to the medium voltage power grid through 500 V or 540 V transformer without N line access, as shown in Figure 2;

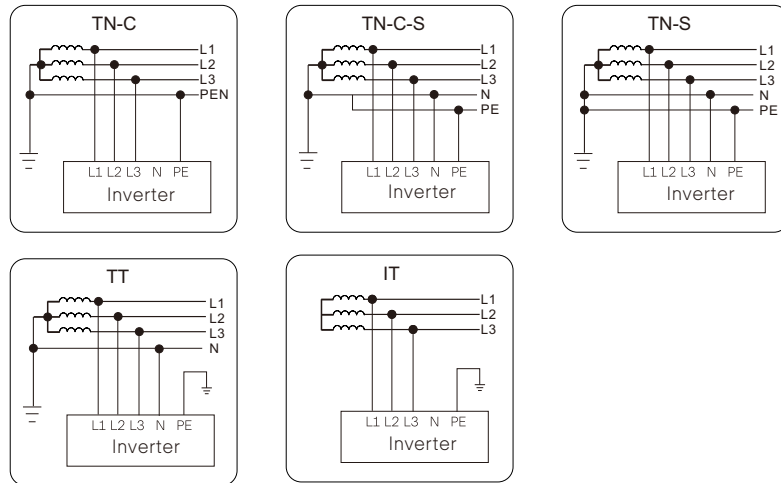

Figure 1

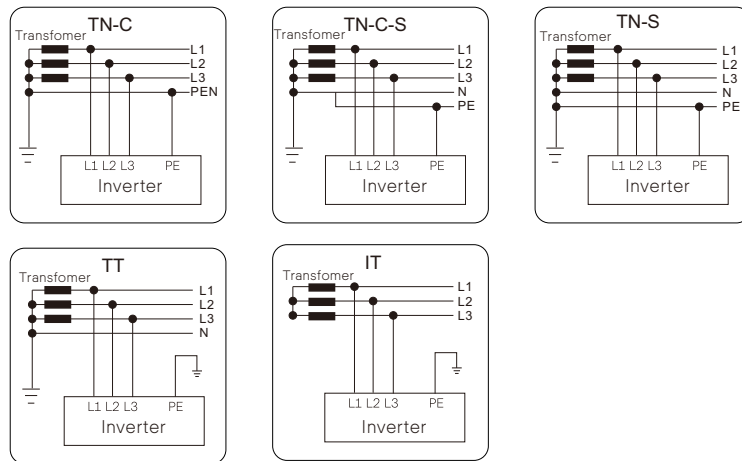

Figure 2

3.2 Basic Features

Thanks for your purchasing with SolaX X3-Forth Series inverter. The X3-Forth Series inverter is one of the finest inverters on the market today, incorporating state-of-the-art technology, high reliability, and convenient control features.

- 2 Strings per MPP tracker, maximum 12 MPP trackers
- Max DC input current 16 A per string, Max DC input current 32 A for each MPP tracker, supporting double side arrays
- Max 150% oversizing DC input power; Max. 110% apparent AC output power
- Remote error diagnoses and firmware upgrade dispatching grid power remotely; reactive power compensating during night
- Smart air cooling, adjustable fan speed
- Current monitoring on each MPP tracker, smart I-V curve scan
- Support electric ARC monitoring (optional), AC output terminal temperature monitoring
- Safety & Reliability: transformerless design with software and hardware protection.
- Power factor regulation.
- Friendly HMI.
 - LED status indications.
 - LCD display technical data, Human-machine interaction through press key.
 - Dry contact communication interface.
 - PC remote control.
 - Remote upgrade and upgrade through USB interface.
 - RS485/PLC communication interfaces available (Optional); WI-FI/4G available
 - Energy conservation.

3.3 Overview of the Inverter

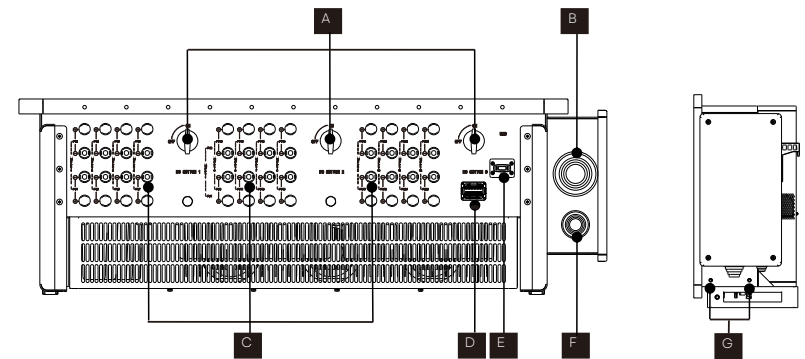

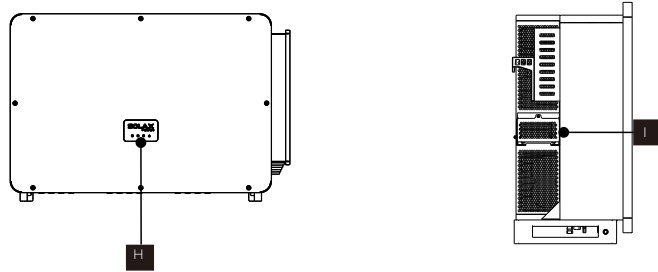

Item	Description
A	DC Switch
B	AC Connector
C	DC Connector
D	RS 485 / Meter / DRM connector (optional)
E	Pocket WiFi / LAN / 4G connector (optional)
F	Ground Connector
G	Ground Screw
H	LED indicator/LCD (optional)
I	Fan support (cooling fan inside)



WARNING!
Only authorized personnel is allowed to set the connection.

3.4 Dimension

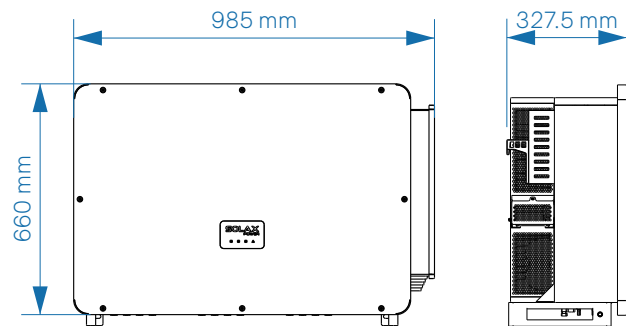

3.5 Principle description

The inverter is equipped with multi-channel MPPT for DC input to ensure maximum power even under different photovoltaic input conditions. The inverter unit converts DC into AC that meets the requirements of the power grid and feeds it into the power grid. The lightning arrester at AC / DC side can realize the function of surge protection.

The principle design of 80K-150K inverter is shown in the figure below:

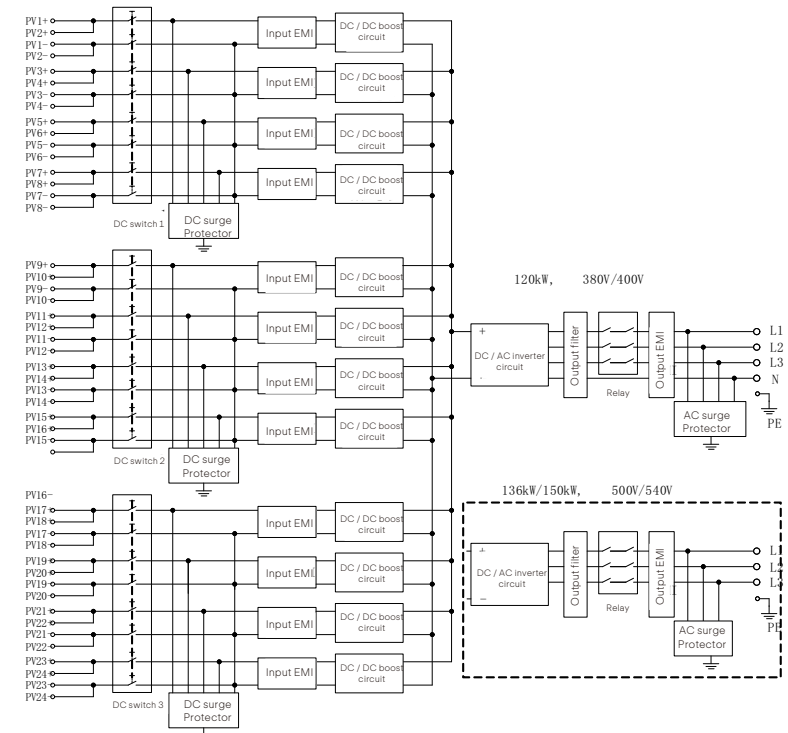

4. Technical Data

4.1 DC Input

➤ DC input of 40k-70k inverter

Model	X3-FTH-40K-LV	X3-FTH-50K-LV	X3-FTH-60K-LV	X3-FTH-70K-LV
Max. DC power [kW]	60	75	90	105
Max. DC voltage [V]	800	800	800	800
Rated DC voltage [V]	360	360	360	360
Start input voltage [V]	200	200	200	200
MPPT voltage range@full load [V]	180-650	180-650	180-650	180-650
Max. DC current [A] / MPPT	32	32	32	32
Max. short circuit current [A] / MPPT	46	46	46	46
No. of MPP trackers	9	9	12	12
Strings of MPP tracker	18	18	24	24

➤ DC input of 80k-150k inverter

Model	X3-FTH-80K	X3-FTH-100K	X3-FTH-110K	X3-FTH-120K	X3-FTH-125K	X3-FTH-136K-MV	X3-FTH-150K-MV
Max. DC power [kW]	120	150	165	180	188	204	225
Max. DC voltage [V]	1100	1100	1100	1100	1100	1100	1100
Rated DC voltage [V]	600	600	600	600	600	730/785	730/785
Start input voltage [V]	200	200	200	200	200	200	200
MPPT voltage range@full load [V]	500-800	500-800	500-800	500-800	500-800	500-800	500-800
Max. DC current [A] / MPPT	32	32	32	32	32	32	32
Max. short circuit current [A] / MPPT	46	46	46	46	46	46	46
No. of MPP trackers	9	9	9	12	12	12	12
Strings of MPP tracker	18	18	18	24	24	24	24

4.2 AC Output

➤ AC output of 40k-70k inverter

Model	X3-FTH-40K-LV	X3-FTH-50K-LV	X3-FTH-60K-LV	X3-FTH-70K-LV
Rated AC power [kW]	40	50	60	70
Rated AC current [A]	105	131.3	157.5	183.7
Max. active power [kW]	44	55	66	70
Max. apparent AC power [VA]	44	55	66	70
Max. AC current [A]	115.5	144.5	173.5	183.7
Nominal AC voltage [V]	220 /127, 3 / N / PE			
Nominal AC frequency [Hz]	50/60 (±5)			
Frequency range of power grid [Hz]	50 (±5)/60 (±5)			
Total harmonic distortion (THDi)	<3% (Rated power)			
DC component of AC current	<0.5% _{I_n}			
Power factor	>0.99 (Rated power)			
Power factor range	0.8 leading-0.8 lagging			

➤ AC output of 80k-150k inverter

Model	X3-FTH-80K	X3-FTH-100K	X3-FTH-110K	X3-FTH-120K	X3-FTH-125K	X3-FTH-136K-MV	X3-FTH-150K-MV
Rated AC power [kW]	80	100	110	120	125	136	150
Rated AC current [A]	121.3/116	151.6/145	166.7/159.5	181.9/174	189.4/181.2	157.1/145.4	173.2/160.4
Max. active power [kW]	88	110	121	132	132	149.6	165
Max. apparent AC power [VA]	88	110	121	132	132	149.6	165
Max. AC current [A]	133.4/127.6	166.7/159.5	183.4/175.4	200/191.3	200/191.3	172.8/160	190.6/176.5
Nominal AC voltage [V]	3 × 220 /380 , 3 × 230 /400 , 3W+(N)+PE					500/540,3P3W+PE	
Grid voltage range [V]	176 - 276 / 304 - 480 *					-	-
Nominal AC frequency [Hz]	50/60						
Frequency range of power grid [Hz]	50 (±5)/60 (±5)						
Total harmonic distortion (THDi)	<3% (Rated power)						
DC component of AC current	<0.5% _{I_n}						
Power factor	>0.99 (Rated power)						
Power factor range	0.8 leading-0.8 lagging						

4.3 Efficiency, Safety and Protection

➤ Efficiency, safety and protection of 40k-70k inverter

Model	X3-FTH-40K-LV	X3-FTH-50K-LV	X3-FTH-60K-LV	X3-FTH-70K-LV
Max. efficiency	98.0%	98.0%	98.0%	98.0%
Safety & Protection				
DC Switch			YES	
DC isolation protection			YES	
Monitoring ground fault protection			YES	
Grid protection			YES	
Over current protection			YES	
Over load protection			YES	
Anti-islanding protection			YES	
DC Surge protection			Type II	
AC Surge protection			Type II	
Residual current detection			YES	
DC injection monitoring			YES	
Over heat protection			YES	

➤ Efficiency, safety and protection of 80k-150k inverter

Model	X3-FTH-80K	X3-FTH-100K	X3-FTH-110K	X3-FTH-120K	X3-FTH-125K	X3-FTH-136K-MV	X3-FTH-150K-MV
Max. efficiency	98.6%	98.6%	98.6%	98.6%	98.6%	99.0%	99.0%
Safety & Protection							
DC Switch						YES	
DC isolation protection						YES	
Monitoring ground fault protection						YES	
Grid protection						YES	
Over current protection						YES	
Over load protection						YES	
Anti-islanding protection						YES	
DC Surge protection						Type II	
AC Surge protection						Type II	
Residual current detection						YES	
DC injection monitoring						YES	
Over heat protection						YES	

4.4 General Data

➤ General data of 40k-70k inverter

Model	X3-FTH-40K-LV	X3-FTH-50K-LV	X3-FTH-60K-LV	X3-FTH-70K-LV
Self-consumption (night)	<10 W			
Isolation type	Non-isolated			
Protective Class	IP66			
Operating temperature range	-25°C~+60°C (derating at +45°C)			
Operation relative humidity	0-100% RH			
Cooling	Smart cooling			
Altitude	4000 m (Derating at 3000)			
Dimension [W/H/D] [mm]	985 × 660 × 327.5			
Weight [kg]	84			
Display	LED indicator × 4, LCD (Optional)			
Communication interfaces	RS485/External WiFi/4G modular (Optional)			
Safety	IEC/EN 62109-1 and 62109-2 (EU)			
EMC	IEC/EN 61000-6-3, IEC/EN 61000-6-4			
Certification	ABNT NBR 16149:2013, ABNT NBR 16150:2013, ABNT NBR IEC 62116: 2012, IEC 61727			
Standard warranty [year]	5years/10years (Optional)			

➤ General data of 80k-150k inverter

Model	X3-FTH-80K	X3-FTH-100K	X3-FTH-110K	X3-FTH-120K	X3-FTH-125K	X3-FTH-136K-MV	X3-FTH-150K-MV
Self-consumption (night)	<10 W						
Isolation type	Non-isolated						
Protective Class	IP66						
Operating temperature range	-25°C~+60°C (derating at +45°C)						
Operation relative humidity	0-100%RH						
Cooling	Forced air cooling						
Altitude	4000 m						
Dimension [W/H/D] [mm]	985 × 660 × 327.5						
Weight [kg]	77			83.3			
Display	LED indicator × 4, LCD (Optional)						
Communication interfaces	RS485/External WiFi/4G modular (Optional)						
Safety	IEC/EN 62109-1 and 62109-2 (EU)						
EMC	IEC/EN 61000-6-1, IEC/EN 61000-6-2, IEC/EN 61000-6-3, IEC/EN 61000-6-4						
Certification	EN 50549, AS4777, VDE4105, IEC 61727, IEC 62116, IEC 61683, IEC 60068, EN 50530						
Standard warranty [year]	5years/10years (Optional)						

Note: AC voltage and frequency ranges may vary depending on the specific state grid.

5. Mechanical Installation

5.1 Installation Precaution



DANGER!

Before installation, make sure there is no electrical connection.
Before drilling holes on the wall, make sure the layout of the water pipes and cables inside the wall is clearly known to avoid any danger.



CAUTION!

Personal injury and machine damage may be caused by improper movement of the inverter.
Please be strictly comply with the instructions of this manual when moving the installing the inverter.

5.2 Selection for the installation position

The installation location selected for the inverter is quite critical in the aspect of the guarantee of machine safety, service life and performance.

- X3-Forth series has the IP66 ingress protection, which allows it to be installed outside the door.
- The installation position shall be convenient for wiring connection, operation and maintenance.

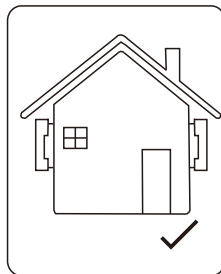

5.2.1 Installation environment required

The installation position shall be well ventilated.

Make sure the installation site meets the following conditions:

- Not be exposed to glare.
- Not in areas where highly flammable materials are stored.
- Not in potential explosive areas.
- Not in the cool air directly.
- Not near the television antenna or antenna cable.
- Not higher than altitude of about 4000m above sea level.
- Not in environment of precipitation or humidity (0-100%) .
- Be sure the ventilation is good enough.
- The ambient temperature in the range of -25°C to +60°C.

Avoid direct sunlight, rain exposure, snow laying up during installing and operating.

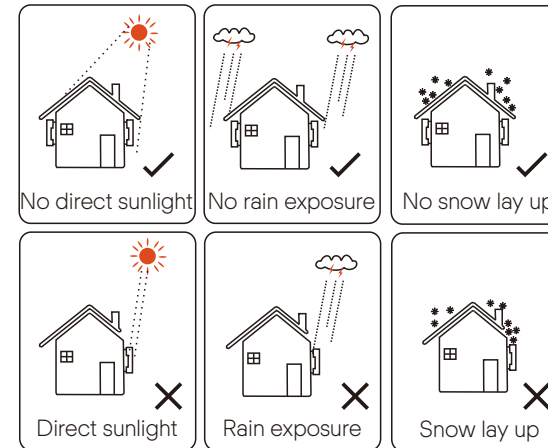

5.2.2 Installation carrier required

The wall or stand hanging the inverter should meet conditions below:

- 1) Solid brick / concrete, or strength equivalent mounting surface;
- 2) Inverter must be supported or strengthened if the strength of wall/stand isn't enough. (such as wooden wall, the wall covered by thick layer of decoration)

5.2.3 Installation angle required

- The inclination angle of the flat installation shall be greater than 10° and can not be tilted forward, inverted, excessive back tilted or side tilted.
- The inverter shall be installed more than 500 mm above the ground.

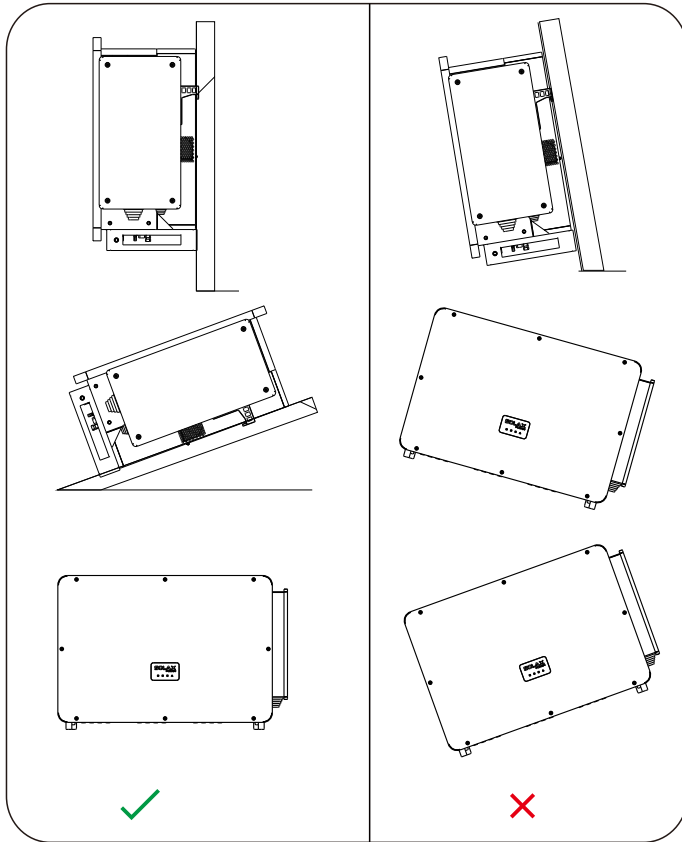

5.2.4 Installation space required



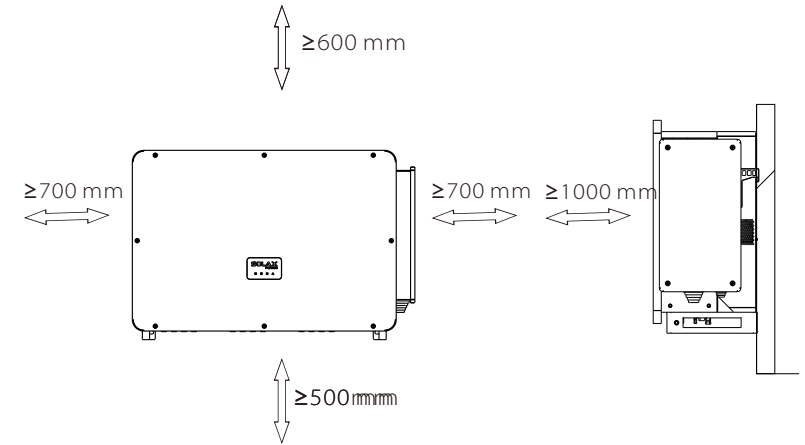



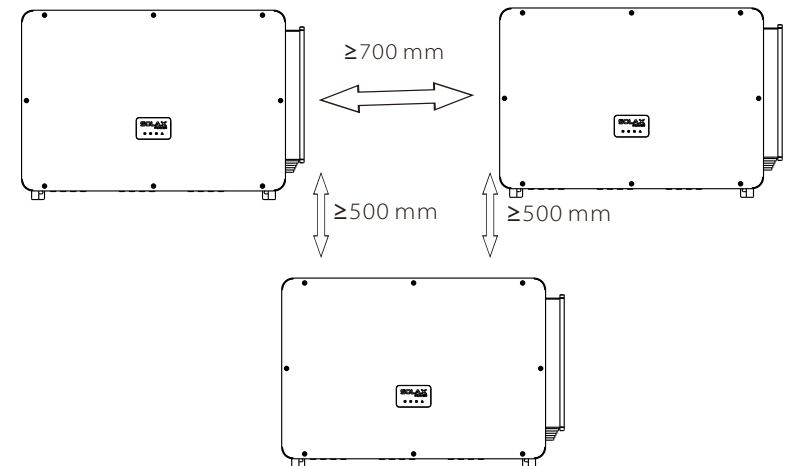



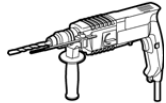

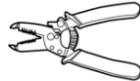

To ensure good heat dissipation and convenient disassembly, the minimum clearance around the inverter shall not be less than the following values, as shown in the following figure.

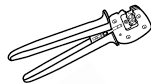



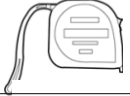

For multi-inverter installation, please reserve the space of 700 mm at least between each left and right inverter and at least 500 mm between each upper and lower inverter.



5.3 Tools preparation for installation and connection

Tool equipment				
Type	Name	Image	Name	Image
Machine Installation Tools	Hammer drill	Bit $\phi 10$ 	Multimeter 	
	Crosshead screwdriver		Torque wrench 	
	Terminals press clamp		Wire stripper 	
	Utility knife		Terminal crimping tool (CT-80) 	
	Crimping Tool		Marker 	
	Rubber hammer		Tape measure 	
	Wire cutter		Digital level 	
	Hot-air blower		Heat-shrnk tubing 	









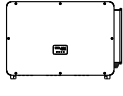

Tool equipment				
Type	Name	Image	Name	Image
Individual Protection Tool	Safety gloves		Safety shoes	
	Protective glasses		Dust cover	

5.4 Check for Transport Damages

Make sure the inverter is intact during transportation. If there are some visible damages, such as cracks, please contact your dealer immediately.

5.5 Packing Lists

Open the package and fetch out the product, check the accessories at first. The packing list shows as below.

 X3-Forth inverter x1	 Bracket x1	 M10xL40 Bolt combination x4
 M8 Bolt x2	 Female DC connector x24 Male DC connectors x24	 Positive DC pin contact x24 Negative DC pin contact x24
 Communication connector x1	 Double offset ring wrench x1	 User manual x1
 Installation guide x1	 WiFi (Optional)	

5.6 Installation steps

5.6.1 Installation steps of mounting the inverter on the wall

➤ Step 1: Fix the bracket on the wall

a) Find out the bracket and M8 bolts from the accessory bag as below:
And prepare M10x80 iron expansion combination in advance. Please kindly note that M10x80 screws are not in the accessory bag. Please prepare them in advance.

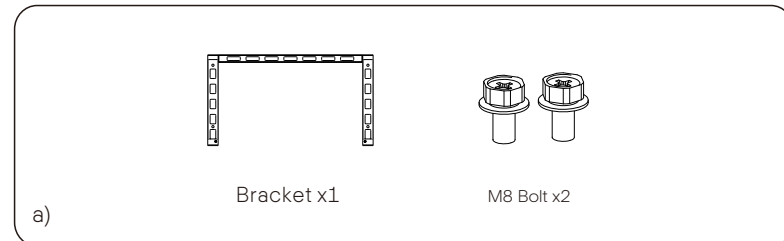

b) Use the bracket as a template for marking the positions of drilling holes on the wall with digital level and marker.

c) Use $\varnothing 10$ drill to drill holes in accordance with the mark. The depth of the holes shall be at least 65 mm.

d) Insert the expansion screws into the holes, hang the bracket on the screw and fix it with nut.

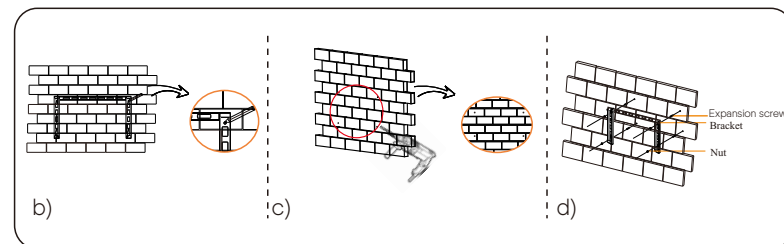

➤ Step 2: Hang the inverter on the bracket

a) Lift up the inverter. Two methods are available for your choice.
Method 1: Four installers directly hold the inverter on the two sides and lift it up.

Method 2: Install two lifting rings on the two sides of inverter and lift it up.

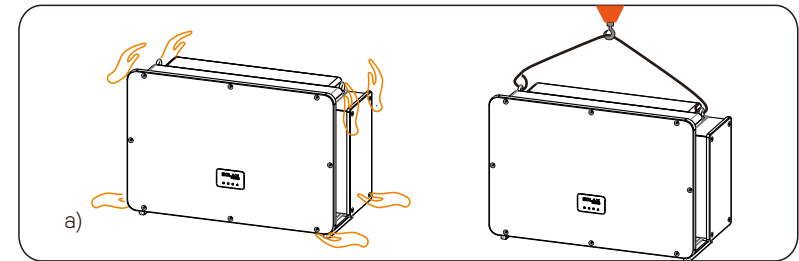

b) Hang the inverter on the bracket and secure it on the bracket with M8 bolts.

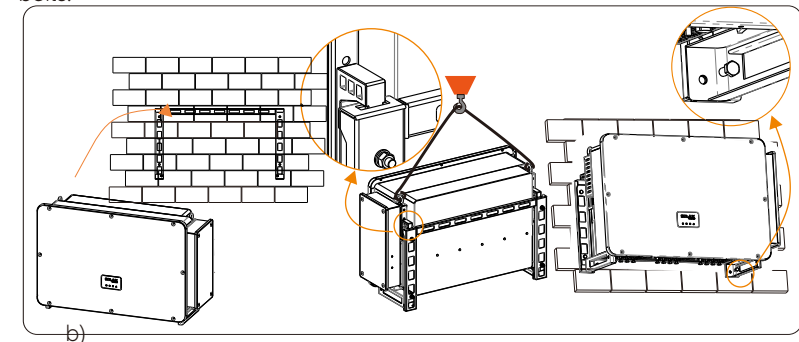

5.6.2 Installation steps of mounting inverter on the stand

➤ Step 1: Fix the bracket on the stand

a) Find out the four M10xL40 bolt combination, bracket and two M8 bolts from the accessory bag as below:

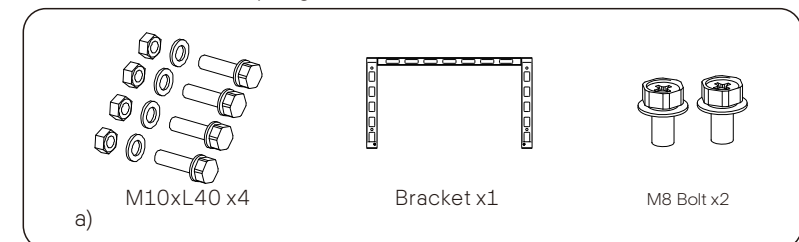

- b) Use the bracket as a template for marking the position of drilling holes on the stand with a digital level and marker.
- c) Use $\phi 10$ drill to drill holes in accordance with the mark. The depth of the holes shall be at least 35 mm.
- d) Pre-install the bracket on the stand and screw in the M10X40 screws.

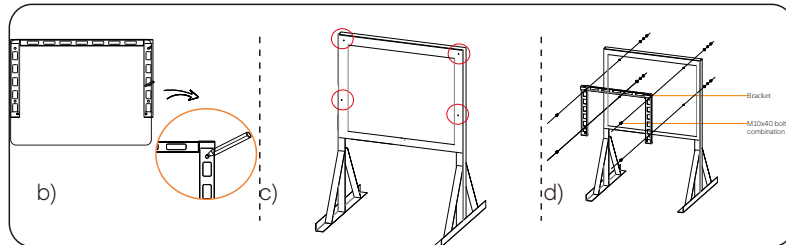

➤ Step 2: Hang the inverter on the bracket

- a) Lift up the inverter. Two methods are available for your choice.
Method 1: Four installers directly hold the inverter on the two sides and lift it up.
Method 2: Install two lifting rings on the two sides of inverter and lift it up.

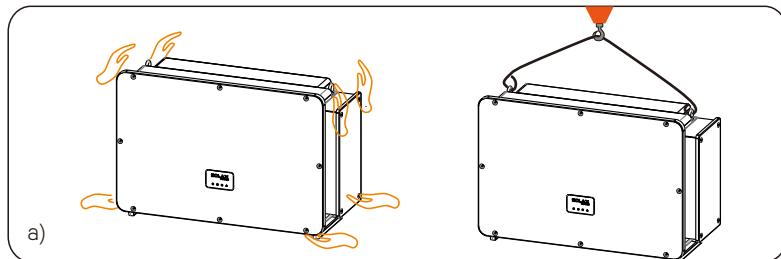

- b) Hang the inverter on the bracket and secure it on the bracket with M8 bolts.

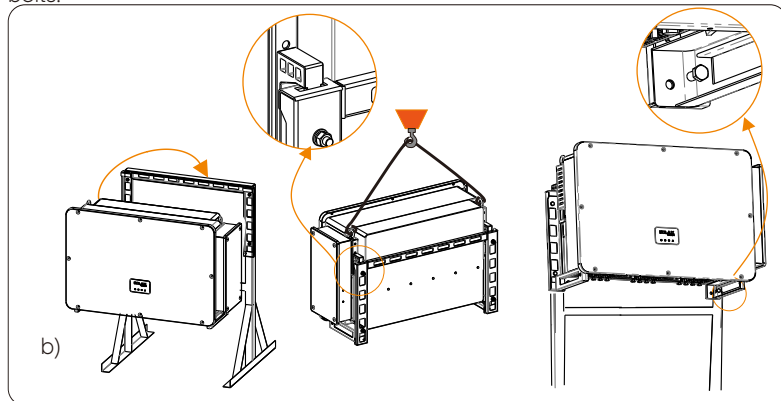

6. Electrical connection

6.1 Grounding connection

The uncharged metal parts in the photovoltaic power generation system, including the photovoltaic substrate bracket and the metal shell of the inverter, should be reliably grounded. The grounding part of multiple inverters and photovoltaic array shall be connected to the same grounding bus to establish reliable equipotential connection.

➤ Step 1: Make the grounding cable

- a) Select 35-70 mm² yellow and green conductor with proper length by wire cutter and OT copper terminal. Use wire stripper to strip the insulation layer of the conductor end. The stripped length shall be as shown below:
- b) Tighten the stripped end and pull the heat-shrink tubing over the grounding cable. The heat-shrink tubing must be at below cable section.

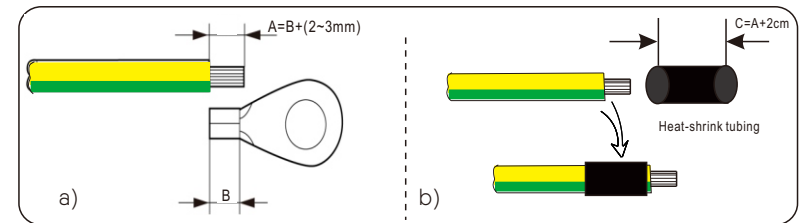

- c) Insert the stripped section into the OT copper terminal and crimp with crimping tool.
- d) Pull the heat-shrink tubing over the stripped section of OT terminal and use hot-air blower to shrink it so that it can be in firm contact with OT terminal.

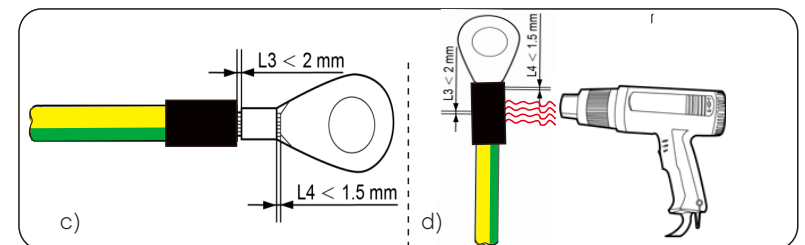

- Step 2: Connect the grounding cable to the inverter.
 - a) Connect the grounding cable to the inverter and fix it with torque 12 N.m

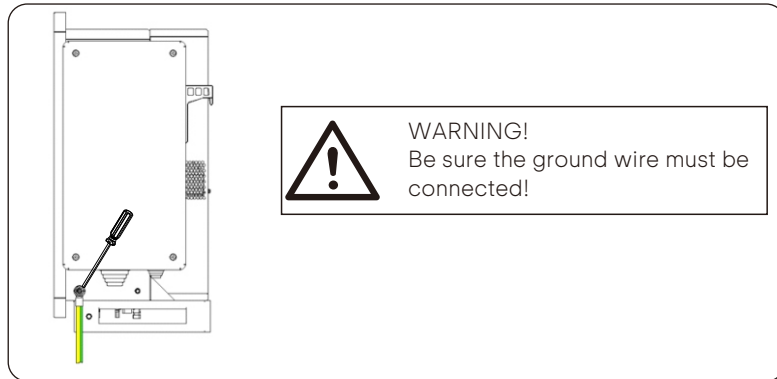

6.2 PV String Connection

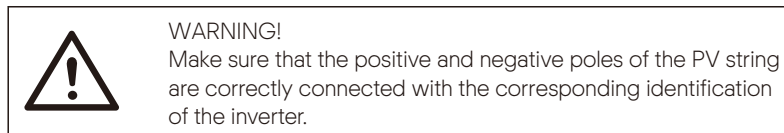
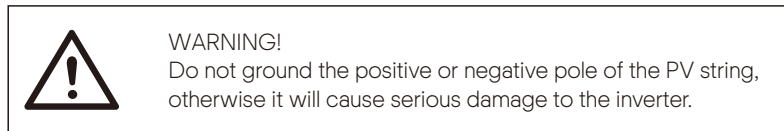
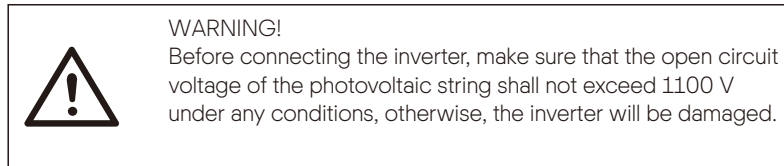

- Step 1: Make the PV cable
 - a) Find out the positive/negative x24 DC connector and x24 positive/negative DC pin contact from accessory bag.

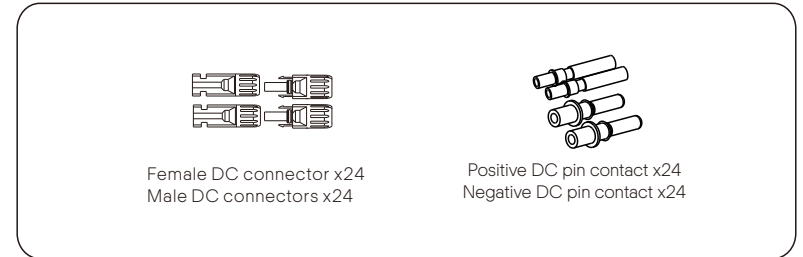

- b) Turn off the DC switch and prepare a 10 AWG PV cable. Use wire stripper to strip 6 mm insulation layer of the PV cable end.

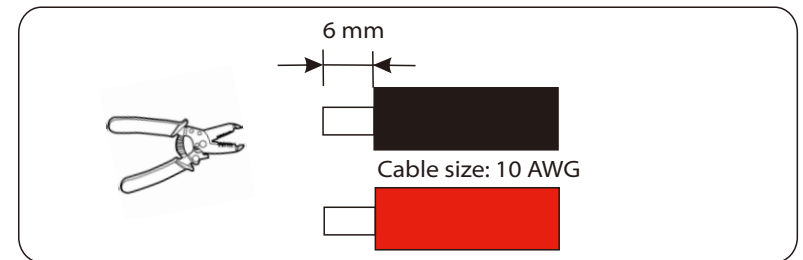

- c) Tighten the stripped section and insert it into the PV pins. And use terminals press clamp to clamp it so that the stripped section of PV cable is in firm contact with PV pins.

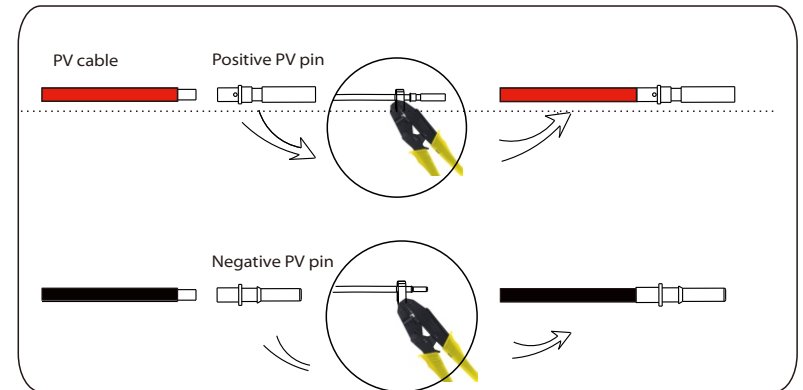

- d) Insert the PV cable through fastening head and plug (male and female) and force the male or female plug to the cable. You will hear "Click" which indicates the connection is completed. Then tighten the fastening head.

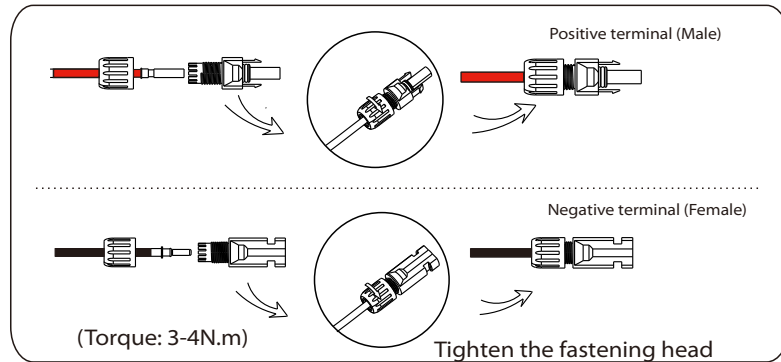

➤ Step 2: Measure the voltage of DC input

Use a multimeter to measure the PV voltage of DC input, verify the polarity of DC input cable, and ensure that the voltage for each string is within the range of inverter.

➤ Step 3: Connect the PV cable to the inverter

Connect the PV cable to the corresponding PV port on the inverter, shown as below:

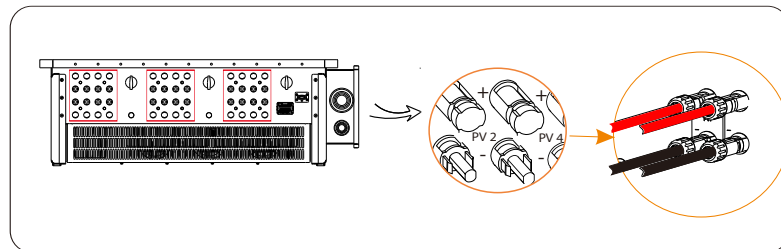

WARNING!
When the DC cable is reversely connected or the inverter fails to work normally, it is forbidden to turn off the DC switch directly or pull out the DC string.

The correct operation is as follows:

- Use clamp current meter to measure DC string current.
- If it is greater than 0.5 A, please wait until the current is less than 0.5 A.
- Only when the current is less than 0.5 A, can the DC power be cut off and the DC string be pulled out.

The inverter damage caused by improper operation will not be included in the warranty.

Requirements for photovoltaic modules connecting to the same circuit:

- All PV modules shall be of the same specification.
- All PV modules have the same tilt angle and orientation.
- The open circuit voltage of the PV string shall not exceed 1100 V at the coldest expected temperature in time

WARNING!
Electric shock!

Do not touch live DC wires. When photovoltaic modules are exposed to light, high voltage will occur, which will lead to the risk of electric shock, resulting in death due to contact with DC conductor.

6.3 Grid Connection

WARNING!
Ensure electrical connection design meets local national and local standards.

WARNING!
The PE wire (ground wire) of the inverter must be reliably grounded.

WARNING!
Disconnect the circuit breaker or fuse of inverter and grid connection access point.

Note:

- It is recommended to add circuit breaker or fuse at AC side, whose specification is more than 1.25 times of rated AC output current.
- 70~240 mm² copper wire is recommended. If aluminum wire is needed, please consult the inverter manufacturer.
- Use copper terminal for copper wire, use copper aluminum terminal for aluminum wire, not aluminum terminal directly.

➤ Step 1: Make the AC cable

a) Select the appropriate OT terminal and black, red and yellow and green cable with proper length by wire cutter, and use wire stripper to strip the insulation layer of the AC cable end. The stripped insulation layer shall be 2-3 mm longer than “D” part of OT terminal.

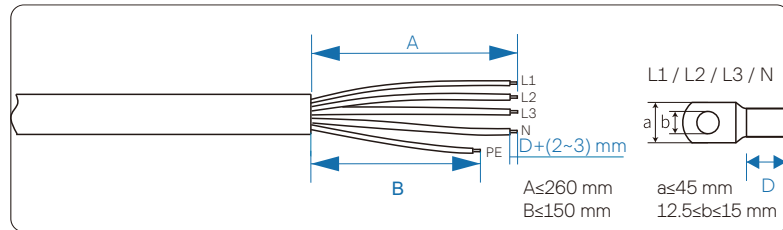

- b) Pull the heat-shrink tubing over AC cable.
- c) Insert the stripped section into OT terminal and crimp with crimping tool and pull the heat-shrink tubing over the crimped section of OT terminal. Then use hot air blower to shrink it so that they are in firm contact with OT terminal.

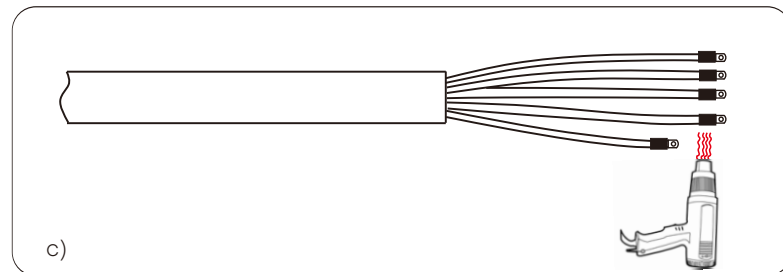
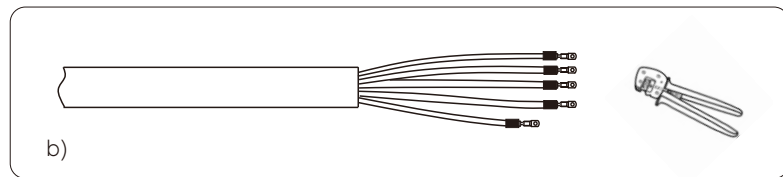

d) Open the cover of the wiring box.

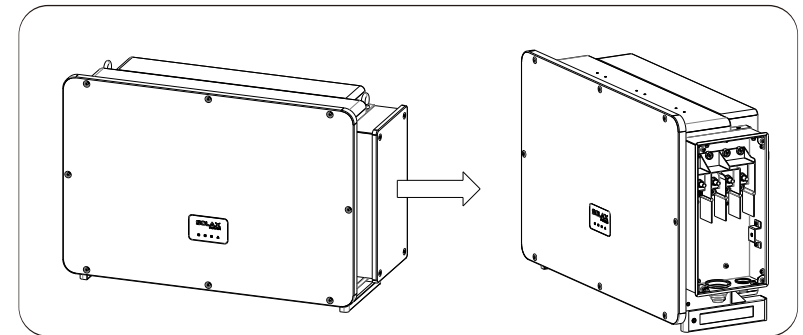

➤ Step 2: Connect the AC cable to the inverter

a) Use utility knife to cut out the pagoda type protection ring in accordance with the whole cable size, route the AC cable through the pagoda protection ring, and connect it to the AC terminals L1, L2, L3 and N in turn, and tighten it with torque wrench (with the torque of 25~30 N·m).

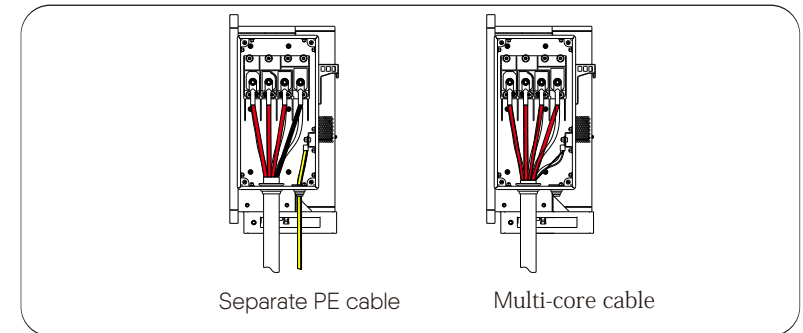

b) Re-install the cover of wiring box and tighten it with screws (with the torque of 5~7 N·m).

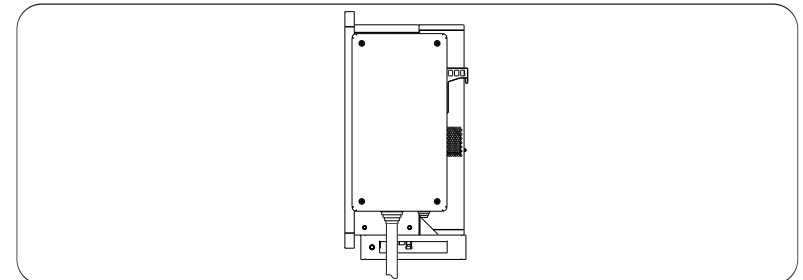

6.4 Communication Connection

6.4.1 Communication signal definition

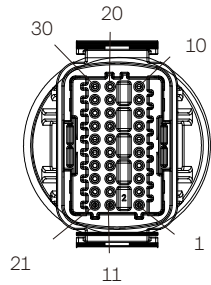

Port	Pin	Definition	Remark
RS-485-1	1	RS485A IN+	Inverter RS485 networking or connect the data collector
	2	RS485B IN-	
	3	Rs485 IN-GND	
	4	RS485A OUT+	
	5	RS485B OUT-	
	6	Rs485 OUT-GND	
RS-485-2	7	RS485A METER	Connect the RS485 meter or other devices
	8	RS485B METER	
	9	V+5V	
	10	COM_GND	
DRM	11	DRM1/5	Reserved for DRM
	12	DRM2/6	
	13	DRM3/7	
	14	DRM4/8	
	15	RG/0	
	16	CL/0	
DI	21	Digital IN+	Input digital signal
	22	Digital IN-	
DO	29	Digital OUT+	Output digital signal
	30	Digital OUT-	

6.4.2 Connection steps of communication cable

a) Find out the communication terminal from the accessory bag and disassemble it into the following parts.

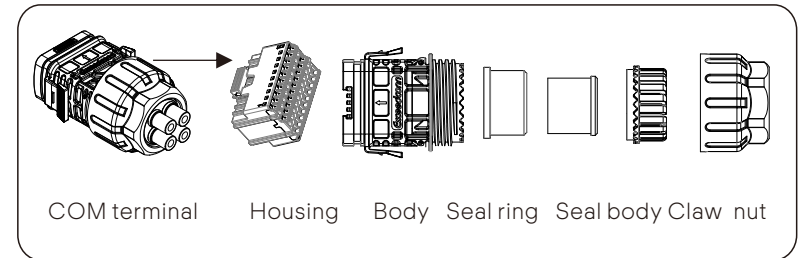

b) Select 0.5-0.75 mm² conductor and use wire stripper to strip 12-14 mm insulation layer of the cable end and insert the insulated cord end terminal to the cable end. (ENY0512 nylon terminal for 0.5 mm²/22 AWG conductor; ENY7515 nylon terminal for 0.75 mm²/20 AWG conductor)

c) Use terminals press clamp to make the terminal in firm contact with the cable end.

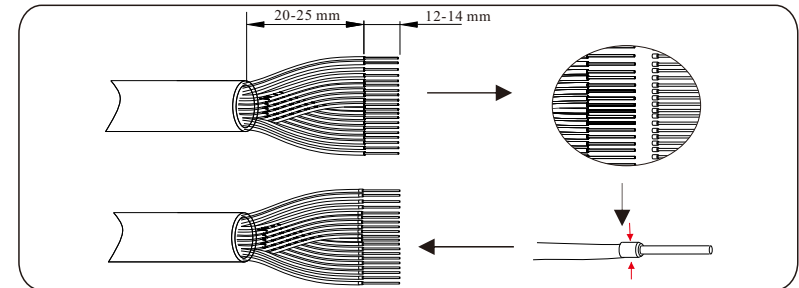

d) Set the nut, claw, seal body, seal ring and body on the communication cable in turn.

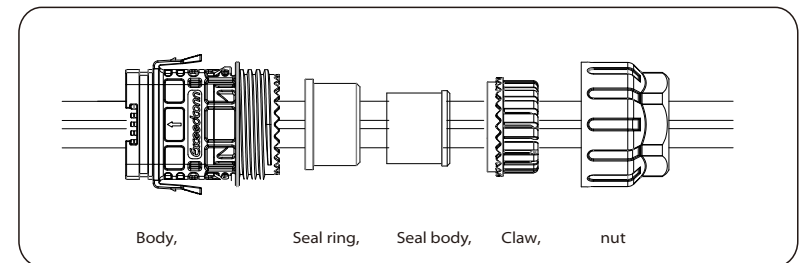

e) Insert the tube type terminal into the housing according to the label on it. Push the terminal-inserted housing into the body. There will be a slight sound of “Click”, which indicates the connection is completed.

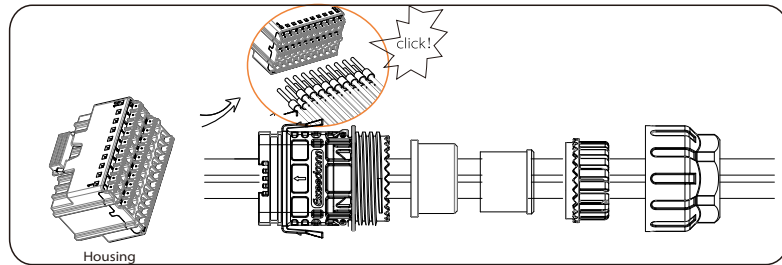

f) Push the seal body into seal ring, then push the claw.
 g) Clockwise tighten the nut with torque 8+/-2 N.m.
 h) Keep the buttons on both sides pressed and connect it to the COM port of the inverter. There will be a slight sound of “Click” if it is correctly connected.

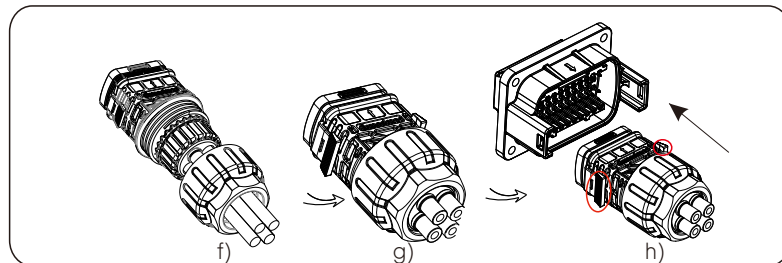

6.4.3 Release steps of communication cable

For releasing the communication cable, please keep the buttons on the two sides pressed and pull out the cable to make it unlocked.

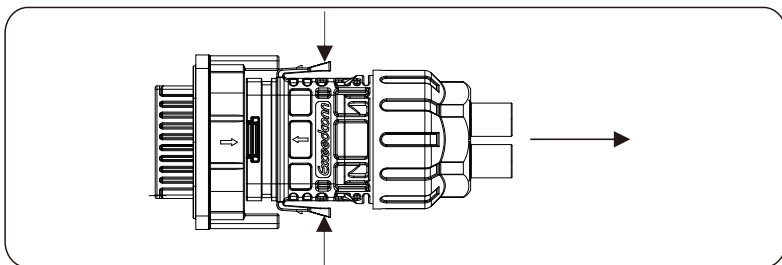

6.5 Monitoring Connection

Solaxcloud is a mobile phone application that can communicate with the inverter via WiFi/LAN/4G. It can realize alarm query, parameter configuration, daily maintenance and other functions. This is a convenient maintenance platform.

Plug Dongle into “USB” port at the bottom of the inverter. After the DC side or AC side is powered on, the APP and inverter can be connected. Please refer to the corresponding manual for details.

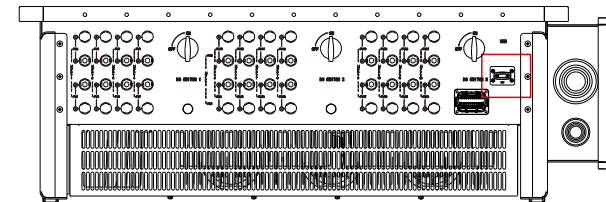

➤ WiFi connection

Solax Pocket WiFi Dongle connects to a local network within 50 m of the installation to enable access to the SolaX Cloud monitoring platform.

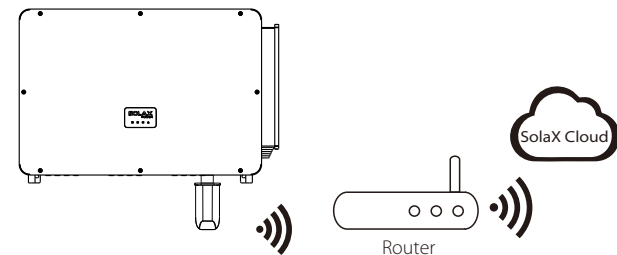

➤ LAN connection

If WiFi isn't suitable, the Pocket LAN enables users to connect to the network via an ethernet cable. Ethernet allows for a much more stable connection with less interference.

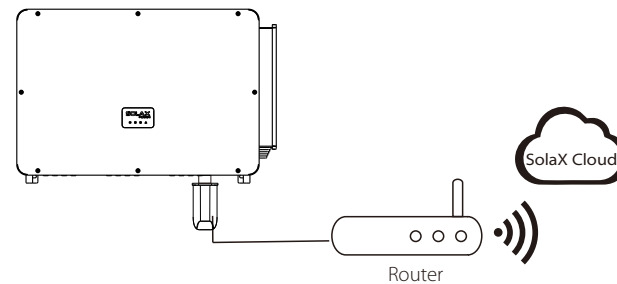

➤ 4G connection

SolaX Pocket 4G dongle allows you to use a 4G connection to monitor your system without the option of connecting to a local network. (This product is not available in the UK)

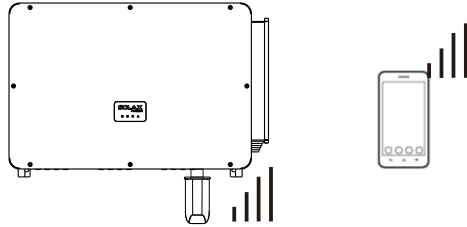

➤ Basic setting and advanced setting

Basic settings include the time, date, language and system switch.

Advanced settings can set the new password of the inverter, buzzer enable, timing switch, etc.

-Under different standard codes, the parameters that can be set for the inverter are different.

-If you change the grid standard code, some parameters may revert to factory defaults. After the grid standard code is changed, please check whether the previously set parameters are affected.

-Sending reset, plant recovery, shutdown or upgrade instructions to the inverter may cause the inverter to be unable to be connected to the grid and affect power generation.

-The power grid parameters, protection parameters, characteristic parameters and power regulation parameters of the inverter must be set by professionals. power grid

Incorrect setting of parameters, protection parameters and characteristic parameters may cause the inverter not connected to the grid and incorrect setting of power adjustment parameters.

-The error may cause that the inverter cannot be connected to the power grid according to the power grid requirements, thus affecting the power generation.

-Parameter name, ranges, and defaults may change or adjust in the future.

7. Start up the Inverter

● Start inverter after checking all below steps:

- Check that device is fixed well on the wall or stand.
- Make sure all the DC breakers and AC breakers are disconnected.
- AC cable is connected to grid correctly.
- All PV panels are connected to inverter correctly, DC connectors which are not used should be sealed by cover.
- Turn on the DC switch to the "ON" position.

● Start the inverter

Inverter will start automatically when PV panels generate enough energy.

Check the status of LED indication

If the LED indication is not on, please check the below:

- All the connections are right.
- All the external circuit breakers are closed.
- The DC switch of the inverter is in the "ON" position.

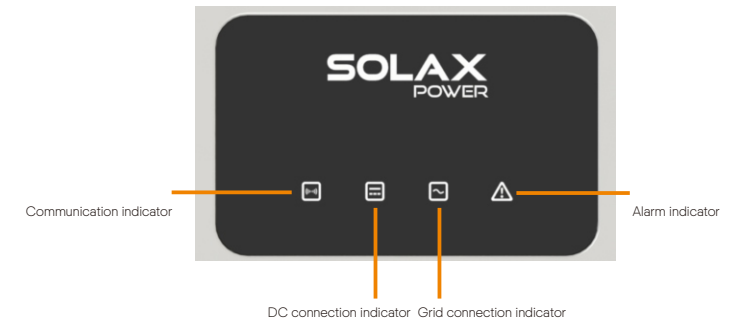

LED	Indicator status	Indicator status definition
Communication signal indicator (blue)	Always light on	The inverter communication is normal.
	Flashing	No communication data is sent or received for a long time.
DC side signal indicator (green)	Always light on	The inverter is in grid-connected state.
	Flashing	If the fault signal light is on, it indicates errors occur on the inverter DC side. If the fault signal light is off, it indicates no errors occur on the inverter DC side and at least one channel of MPPT input voltage is higher than 200 V.
	Always light off	The input voltage of all channels of MPPT is less than 200 V; Or DC switch is not turned on.
Grid connection indicator (green)	Always light on	The inverter is in grid-connected state.
	Flashing	If the fault signal indicator is on, it indicates errors occur on inverter AC side; If the fault signal indicator is off, AC grid is connected and the inverter is not in grid-connected state.
	Always light off	The inverter is not connected to the grid;
Inverter fault indicator (Red)	Always light on	The inverter is faulty
	Flashing	The inverter prompts warning
	Always light off	The inverter is currently in a normal state, and there is no fault.

- Four LED lights have three states:

Always on / always off / flashing

The specific definitions are as follows:

Note:

When there is firmware in the inverter system in the upgrading state, the other 3 LED lights are in the flashing state except the communication signal light; Do not operate the inverter before upgrading finished.

8 Troubleshooting

8.1 Troubleshooting

This section contains information and procedures for solving possible problems with X3 series inverters, and provides you with troubleshooting tips to identify and solve most problems that could occur with the X3 series inverters.

This section will help you narrow down the source of any problems you may encounter. Please read the following troubleshooting steps.

Check warnings or fault messages on System Control Panel or Fault codes on the inverter information panel. If a message is displayed, record it before doing anything further.

Attempt the solution indicated in troubleshooting lists.

If your inverter's information panel is not displaying a Fault light, check the following list to make sure that the present state of the installation allows proper operation of the unit.

- Is the inverter located in a clean, dry, adequately ventilated place?
- Have the DC input breakers been opened?
- Are the cables adequately sized and short enough?
- Are the input and output connections and wiring in good condition?
- Are the configurations settings correct for your particular installation?
- Are the display panel and the communications cable properly connected and undamaged?

Contact SolaX Customer Service for further assistance. Please be prepared to describe details of your system installation and provide model and serial number of the unit.

Global Service Center: +86 (571) 56260033 ext 749

General Enquiry: +86 (571) 56260011

Sales Enquiry: +86 (571) 56260008

E-Mail: info@solaxpower.com

Fax: +86 (571) 56075753

error	Diagnostics and Solutions
ISO_Fail	PV insulation impedance below safety value 1. Check PV electrical connection; 2. Check the grounding of inverter; 3. Contact the installer;
Meter_Oppsite	Incorrect meter direction 1. Confirm whether the current direction of the meter is correct; 2. Contact the installer
Remote_Off	The inverter receives the shutdown command and is in the shutdown state 1. Send the startup command through app or web to re run the inverter; 2. Contact the installer
Freq_Cfg_Err	Grid rated frequency setting error 1. Check whether the state / power grid directive is set correctly; 2. Contact the installer
Gnd_Conn_Err	Inverter grounding fault 1. Check whether the Neutral line of the power grid is correctly connected; 2. Check whether the inverter ground wire is correctly connected; 3. Try to re run the inverter; 4. Contact the installer;
PV01_Reverse	Reversed PV connection on MPPT1 (PV01-PV12 respectively represent the PV input channel 1-12) 1. Check whether the electrical connection of PV module is correct; 2. Contact the installer
PV_VolHigh	PV input voltage is higher than the allowable value (PV1-PV12 respectively represents 1-12 PV overvoltage) 1. Check the PV voltage and confirm that it is within the allowable range; 2. Reduce the number of PV modules in series and reduce PV voltage; 3. Contact the installer
BST_SW_OCP	MPPT software overcurrent 1. Check whether the PV input is short circuited; 2. Try to restart the inverter; 3. Contact the installer
BST_HW_OCP	MPPT hardware overcurrent 1. Check whether the PV input is short circuited; 2. Try to restart the inverter; 3. Contact the installer
Grid_Loss	Power failure of power grid / disconnection of AC line or AC switch. 1. Check whether the grid voltage is normal; 2. Check the power grid electrical connection AC switch; 3. Try to restart the inverter
GridVol_OP1	The grid voltage exceeds the allowable value 1. Check whether the grid voltage is within the allowable range; 2. Try to re run the inverter;
GridVol_UP1	The grid voltage is lower than the allowable value 1. Check whether the grid voltage is within the allowable range; 2. Try to re run the inverter;
GridVol_OP_10M	The average grid voltage in 10 minutes exceeds the allowable value 1. Check whether the grid voltage is within the allowable range; 2. Try to re run the inverter;

error	Diagnostics and Solutions
GridVol_OP_INST	Instantaneous high voltage of power grid 1. Check whether the grid voltage is within the allowable range; 2. Try to re run the inverter;
GridFreq_OP1	Grid frequency exceeds allowable value 1. Check whether the power grid frequency is within the allowable range; 2. Try to re run the inverter;
GridFreq_UP1	The grid frequency is lower than the allowable value 1. Check whether the power grid frequency is within the allowable range; 2. Try to re run the inverter;
GridPhase_Loss	Loss of grid phase voltage 1. Check the grid voltage; 2. Check the power grid electrical connection AC switch; 3. Try to re run the inverter
Grid_Unbalance	Grid voltage imbalance 1. Check whether the grid voltage is within the allowable range; 2. Try to re run the inverter;
Grid_FRT	Grid fault 1. Check whether the grid voltage is within the allowable range; 2. Try to re run the inverter;
DCBus_HW_OVP	Bus hardware overvoltage 1. Check the PV voltage and confirm that it is within the allowable range; 2. Try to restart the inverter; 3. Contact the installer
PBus_FSW_OVP	Bus software overvoltage 1. Try to restart the inverter; 2. Contact the installer
NBus_FSW_OVP	Bus software overvoltage 1. Try to restart the inverter; 2. Contact the installer
DCBus_SW_OVP	Bus software overvoltage 1. Check the PV voltage and confirm that it is within the allowable range; 2. Try to restart the inverter; 3. Contact the installer
DCBus_SW_UVP	Bus software undervoltage 1. Check the PV voltage and confirm that it is within the allowable range; 2. Try to restart the inverter; 3. Contact the installer
DCBus_Unbalance	Bus imbalance 1. Try to restart the inverter; 2. Contact the installer
PV_Above_Bus	The PV voltage is higher than the Bus voltage 1. Try to restart the inverter; 2. Contact the installer

error	Diagnostics and Solutions
DcBus_SSErr	Bus soft start failure 1. Try to restart the inverter; 2. Contact the installer
SunPWR_Weak	Low PV power 1. Try to restart the inverter; 2. Contact the installer
InvRelay_Err	Relay fault 1. Try to restart the inverter; 2. Contact the installer
Relay_OnErr	Relay pull in fault 1. Try to restart the inverter; 2. Contact the installer
Inv_SW_OCP	Inverter software overcurrent 1. Try to restart the inverter; 2. Contact the installer
Inv_PkCur_OL	Inverter peak overcurrent fault 1. Try to restart the inverter; 2. Contact the installer
Inv_HW_OCP	Inverter hardware overcurrent 1. Try to restart the inverter; 2. Contact the installer
Inv_DCI_Err	DCI exceeds allowable value 1. Try to restart the inverter; 2. Contact the installer
Inv_SC_Err	Inverter peak overcurrent fault 1. Try to restart the inverter; 2. Contact the installer
GFCI_CT_Err	GFCI sensor failure 1. Try to restart the inverter; 2. Contact the installer
GFCI_Err	GFCI failure 1. Check whether the inverter ground wire is correctly connected; 2. Try to restart the inverter; 3. Contact the installer
Inv_HW_OCPA	Inverter hardware overcurrent fault 1. Try to restart the inverter; 2. Contact the installer
Bst_IGBT_NTC_OTP	Boost module temperature above allowable value 1. Confirm that the inverter is well ventilated; 2. Try to restart the inverter; 3. Contact the installer

error	Diagnostics and Solutions
Inv_IGBT_NTC_OTP	The temperature of inverter module is higher than the allowable value 1. Confirm that the inverter is well ventilated; 2. Try to restart the inverter; 3. Contact the installer
AC_TB_NTC_OTP	The AC terminal temperature is higher than the allowable value 1. Confirm that the inverter is well ventilated; 2. Try to restart the inverter; 3. Contact the installer
Envir_Tmp_High	The internal temperature is higher than the allowable value 1. Confirm that the AC terminal of the inverter is well wired; 2. Try to restart the inverter; 3. Contact the installer
Envir_Tmp_Low	The internal temperature is lower than the allowable value 1. Confirm that the inverter is well ventilated; 2. Try to restart the inverter; 3. Contact the installer
TmpSensor_Loss	Temperature sensor connection failure 1. Try to restart the inverter; 2. Contact the installer
Comm_SPI_Err	Internal SPI failure 1. Try to restart the inverter; 2. Contact the installer
Comm_CAN_Err	Internal CAN failure 1. Try to restart the inverter; 2. Contact the installer
EPRM_RW_Err	EEPROM fault 1. Try to restart the inverter; 2. Contact the installer
FAN1_Err	Fan 1 fault 1. Try to restart the inverter; 2. Contact the installer
FAN2_Err	Fan 2 fault 1. Try to restart the inverter; 2. Contact the installer
MOV_AC_Err	AC lightning protection module failure 1. Try to restart the inverter; 2. Contact the installer
MOV_DC_Err	DC lightning protection module failure 1. Try to restart the inverter; 2. Contact the installer
Type_Model_Err	Model setting error 1. Try to restart the inverter; 2. Contact the installer
SW_VerMismatch	Software version unmatched error 1. Try to restart the inverter; 2. Contact the installer

8.2 Routine Maintenance

Inverters do not need any maintenance or correction in most condition, To ensure that the X3-Forth can operate properly for a long term, you are advised to perform routine maintenance on it. Before cleaning the system, connecting cables, and maintaining the grounding reliability, power off the system.

• Fan Maintenance

The external fan of inverter is in operation for a long time. In order to keep the fan in normal working state, it is necessary to clean the fan regularly (it is recommended to clean it once a year).

If the service life is too long, the fan may fail, and the fan needs to be repaired or replaced. The maintenance or replacement requires professional operation.

Step 1. Before maintenance of fan, the AC connection must be disconnected, then the DC switch must be disconnected and wait 5 minutes till the inverter is completely OFF.

Step 2. Remove the fan support fixing screw as shown in the figure below.

Step 3. Pull out the fan bracket, stop at the position about 150 mm, then pull off the fan waterproof connector, then pull the fan bracket again to pull out the whole bracket.

Step 4. Clean, repair, or replace the fan.

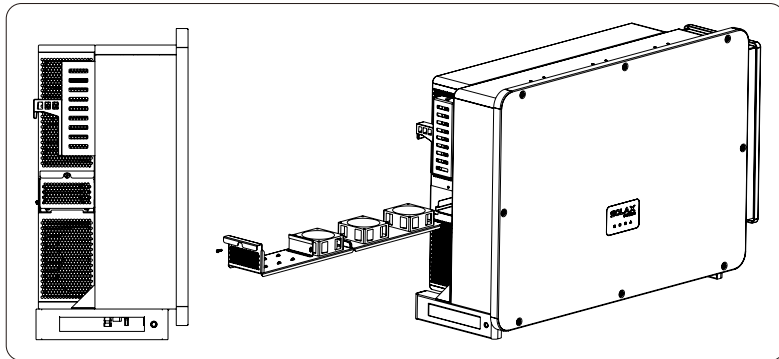

• Safety checks

Safety checks should be performed at least every 12 months by manufacturer's qualified person who has adequate training, knowledge, and practical experience to perform these tests. The data should be recorded in an equipment log. If the device is not functioning properly or fails any of test, the device has to be repaired. For safety check details, refer to this manual, section 2 Safety instruction and EC Directives.

• Maintain periodically

Only qualified person may perform the following works.

During the process of using the inverter, the manage person shall examine and maintain the machine regularly. The concrete operations are follow.

1) Check that if the cooling fins on the rear of inverter are covered by dirt, and the machine should be cleaned and absorbed dust when necessary.

This work shall be check from time to time.

2) Check that if the indicators of the inverter are in normal state, check if the display of the inverter (if it has screen) is normal. This check should be performed at least every 6 months.

3) Check that if the input and output wires are damaged or aged. This check should be performed at least every 6 months.

4) Check whether the ground terminal and ground cable are securely connected and all terminals and ports are properly sealed. This check should be performed at least every 6 months.

5) You should get the inverter panels cleaned and their safety checked at least every 6 months.

9 Decommissioning

9.1 Dismantling the Inverter

- Switch off the DC and AC switch/breaker and disconnect the inverter from DC Input and AC output.
- Wait for 5 minutes for de-energizing.
- Disconnect communication and optional connection wirings.
- Remove the inverter from the bracket.



WARNING!

Before dismantling the inverter, please be sure to disconnect the DC switch, and then unplug the PV and AC cables, otherwise it will lead to an electric shock hazard.

9.2 Packaging

If possible, please pack the inverter with the original packaging.

If it is no longer available, you can also use an equivalent carton that meets the following requirements.

- Suitable for loads more than 80 kg.
- With handle.
- Can be fully closed.

9.3 Storage and Transportation

Store the inverter in dry place where ambient temperatures are always between -25°C - $+60^{\circ}\text{C}$. Take care of the inverter during the storage and transportation, keep less than 4 cartons in one stack.

When the inverter or other related components need to be disposed. Have it carried out according to local waste handling regulations. Please be sure to deliver wasted inverters and packing materials to certain site, which can assist relevant department to dispose and recycle.

9.4 Disposing of the X3-Forth

If the X3-Forth service life expires, dispose of it according to the local disposal rules for electrical equipment waste.

10 Disclaimer

X3 series inverters are transported, used and operated under limited condition, such as environmental, electrical etc. SolaX shall not be liable to provide the service, technical support or compensation under conditions listed below, including but not limited to:

- Inverter is damaged or broken by force majeure (such as earthquake, flooding, thunderstorm, lighting, fire hazard, volcanic eruption etc).
 - Inverter's warranty is expired and doesn't buy extended warranty.
 - Can't provide the inverter's SN, warranty card or invoice.
 - Inverter is damaged by man-made cause. Inverter is used or operated against any items in local policy.
 - Inverter's installation, configuration, commissioning doesn't follow the requirements mentioned in this manual.
 - Inverter is installed, refitted or operated in improper ways mentioned in this manual without authority from SolaX.
 - Inverter is installed, operated under improper environment or electrical condition mentioned in this manual without authority from SolaX.
 - Inverter is changed, updated or disassembled on hardware or software without authority from SolaX.
 - Obtain the communication protocol from other illegal channels.
 - Build monitoring, control system without authority from SolaX.
 - Connect to other brands batteries without authority from SolaX.
- SolaX will keep right to explain all the contents in this user manual.

Warranty Registration Form



For Customer (Compulsory)

Name Country

Phone Number Email

Address

State Zip Code

Product Serial Number

Date of Commissioning

Installation Company Name

Installer Name Electrician License No.

For Installer

Module (If Any)

Module Brand

Module Size(W)

Number of String Number of Panel Per String

Battery (If Any)

Battery Type

Brand

Number of Battery Attached

Date of Delivery Signature

Please visit our warranty website: <https://www.solaxcloud.com/#/warranty> to complete the online warranty registration or use your mobile phone to scan the QR code to register.

For more detailed warranty terms, please visit SolaX official website: www.solaxpower.com to check it.





PLEASE REGISTER THE WARRANTY IMMEDIATELY AFTER INSTALLATION!
GET YOUR WARRANTY CERTIFICATE FROM SOLAX!
KEEP YOUR INVERTER ONLINE & WIN SOLAX POINTS!

1

Open your camera app and point your device at the QR code



2

Wait for the camera to recognize the QR code



3

Click banner or notification when it appears on the screen



4

Warranty registration page will be loaded automatically

